

VOGLIA DI CRESCERE

PROGRAMMA BASE PER LO SVILUPPO LOGICO E COGNITIVO

Emidio Tribulato

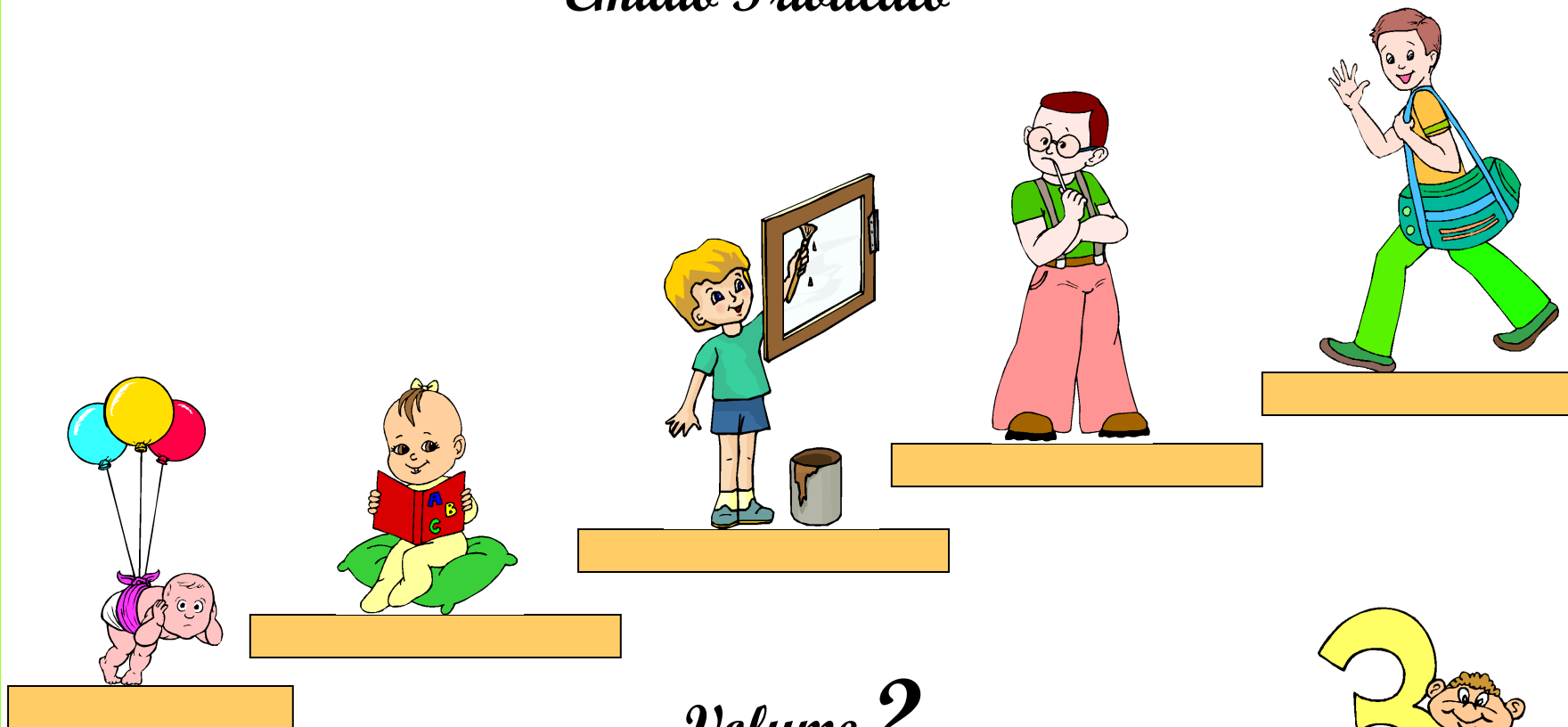

Volume 2

Livello



CENTRO STUDI LOGOS
ONLUS
CENTRO DI RICERCHE PSICOPEDAGOGICHE
VIA PRINCIPE TOMMASO 2 - MESSINA
TEL. 090/46920
DIRETTORE: DOTT. EMIDIO TRIBULATO

“ VOGLIA DI CRESCERE ”

PROGRAMMA BASE PER LO SVILUPPO LOGICO E COGNITIVO

Emidio Tribulato

INDICE

IL VOCABOLARIO	Pag. 3
ASSOCIAZIONI DI IMMAGINI UGUALI O SIMILI	“ 43
LINGUAGGIO: ASSOCIAZIONI VERBALI	“ 177



2005 - Tutti i diritti riservati. Emidio Tribulato Viale Annunziata 72
Messina – Tel. 090357149 - 09046920

Vol. II

Il livello 3

SIGLATURA

Per avere una visione immediata di come procede, nel minore, l'apprendimento è bene che questo venga evidenziato mediante dei simboli.

E' fondamentale, infatti, che l'educatore abbia presente, in ogni momento, quali schede o attività siano dal bambino conosciute, sconosciute o in via di acquisizione. Ciò per evitare di farlo confrontare con temi troppo complessi senza aver prima consolidato gli apprendimenti più semplici, o di far ripetere inutilmente schede e attività da lui perfettamente conosciute e quindi superate.

Si consiglia pertanto di siglare sia le singole schede che le attività globali indicate nell'indice sottostante indicando con:

 un puntino l'inizio dell'apprendimento;

 una crocetta, le schede o le attività in cui il bambino dà risposte esatte ma senza il commento verbale minimo richiesto, ad esempio il nome dell'oggetto;

 un cerchio che circonda una crocetta, per indicare le schede o le attività in cui il bambino dà un commento verbale minimo.

 un quadrato che include un cerchio ed una crocetta, per indicare le schede o le attività di cui il bambino ha completato l'apprendimento.

LIVELLI DI APPRENDIMENTO

- IL VOCABOLARIO
- ASSOCIAZIONI DI IMMAGINI UGUALI O SIMILI
- LINGUAGGIO: ASSOCIAZIONI VERBALI

“ VOGLIA DI CRESCERE ”

PROGRAMMA BASE PER LO SVILUPPO LOGICO E COGNITIVO

IL VOCABOLARIO

IL VOCABOLARIO

Nei bambini con insufficienza mentale, svantaggiati o nei bambini sordi, la comprensione delle parole è limitata ad un numero molto ridotto di queste.

E' invece fondamentale per una maggiore ricchezza culturale e per una conseguente maggiore comprensione del testo scritto, saper riconoscere molti oggetti, animali o vegetali e verbalizzare il loro nome.

L'album che presentiamo si prefigge questo scopo.

UTILIZZAZIONE

Per i sordi che incominciano a leggere.

1^a Fase.

Il bambino leggendo le brevi frasi in cui è presente il soggetto e l'articolo dovrà indovinare a quale immagine si riferisce.

2^a Fase.

Lasciando scoperta la parte inferiore della scheda e indicando le varie immagini si chiederà al bambino di dire il nome dell'oggetto.

3^a Fase.

Coprendo la parte inferiore della scheda il bambino dovrà verbalizzare il nome del soggetto.

4^a Fase.

Il bambino dovrà indicare, attraverso la lettura labiale, l'immagine alla quale si riferisce l'educatore.

Per i bambini con insufficienza mentale o svantaggio socio-culturale è più utile utilizzare un altro tipo di metodologia.

1^a Fase - Comprensione verbale.

L'educatore presenta le immagini della scheda dicendo il nome dell'oggetto e le sue caratteristiche.

2^a Fase - Comprensione verbale.

Il bambino dovrà indicare l'immagine corrispondente a quella richiesta dall'educatore.

3^a Fase - Espressione verbale.

L'educatore indicando ogni soggetto chiederà al bambino il suo nome.

I bambini che sanno leggere e scrivere, potranno loro stessi collegare la frase all'immagine corrispondente e quindi, in un momento successivo, coprendo la parte inferiore della scheda, potranno scrivere il nome dell'oggetto rappresentato.

ETA' MENTALE DI RIFERIMENTO

Tre anni nello sviluppo logico e linguistico.

IL VOCABOLARIO

Far associare le singole parole all'immagine corrispondente.

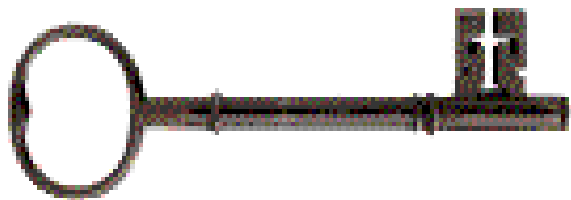
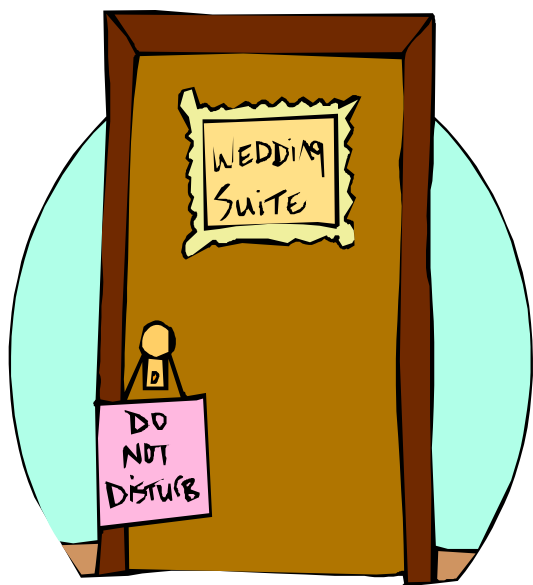

- La chiave.
- Il lucchetto.
- La porta.

IL VOCABOLARIO

Far associare le singole parole all'immagine corrispondente.

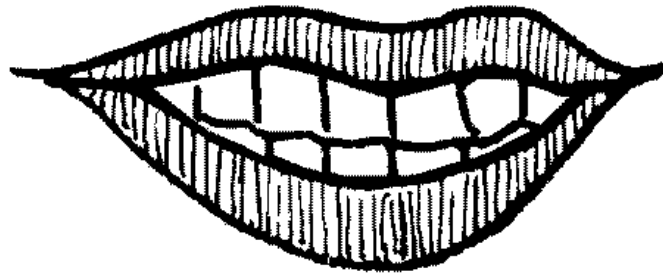
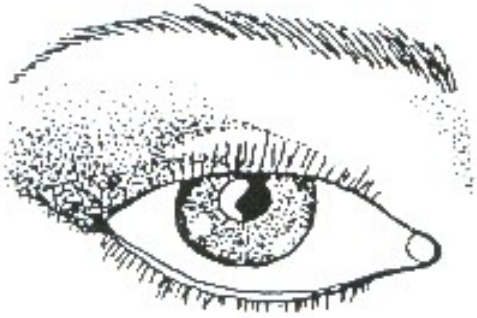

- L'occhio.
- L'orecchio.
- La bocca.

IL VOCABOLARIO

Far associare le singole parole all'immagine corrispondente.

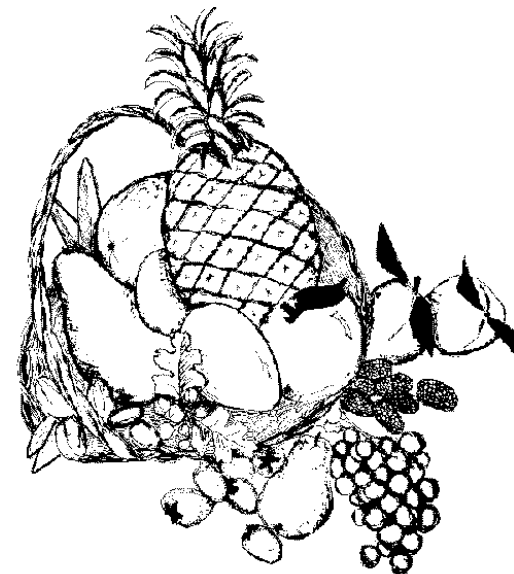
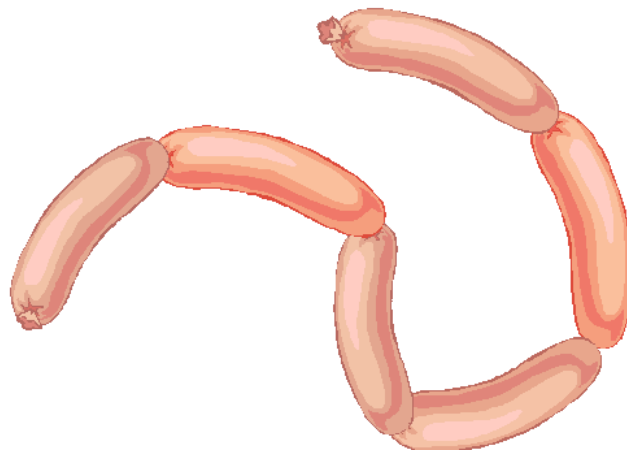
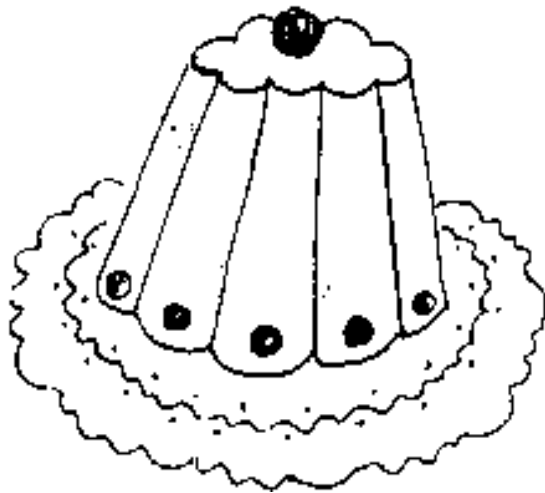

- La frutta.
- La salsiccia.
- Il dolce.

IL VOCABOLARIO

Far associare le singole parole all'immagine corrispondente.

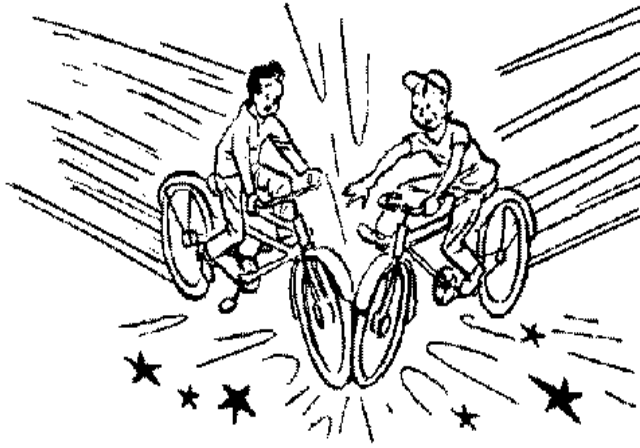

- Sbadigliare.
- Comprare.
- Scontrarsi.

IL VOCABOLARIO

Far associare le singole parole all'immagine corrispondente.

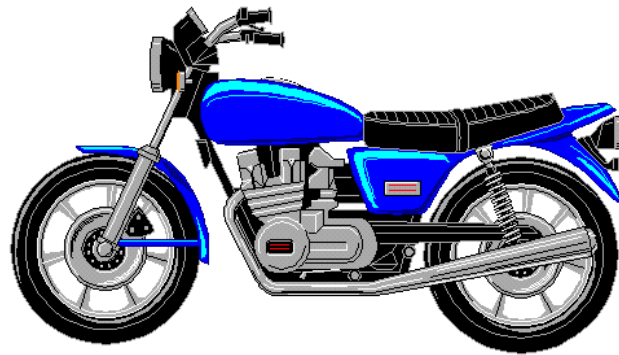

- La motocicletta.
- Il camion.
- L'autobus.

IL VOCABOLARIO

Far associare le singole parole all'immagine corrispondente.

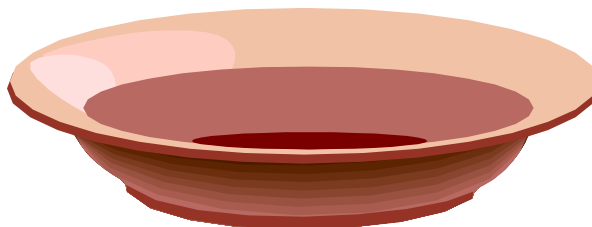
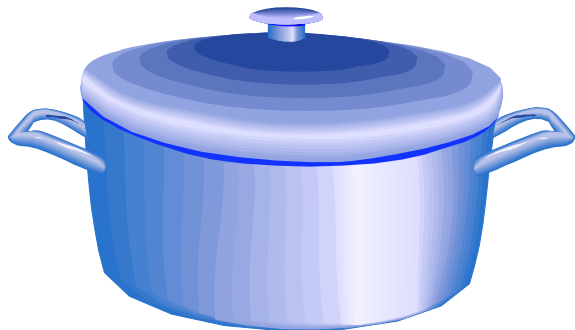

- La pentola.
- Il piatto.
- Il cucchiaino.

IL VOCABOLARIO

Far associare le singole parole all'immagine corrispondente.



- Accarezzare.
- Pitturare.
- Implorare.

IL VOCABOLARIO

Far associare le singole parole all'immagine corrispondente.

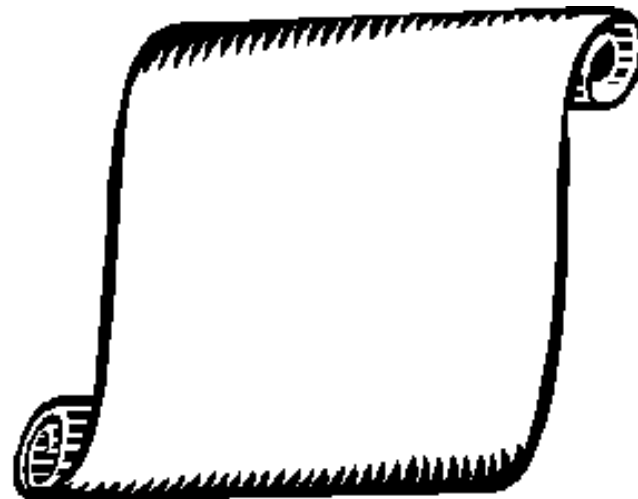
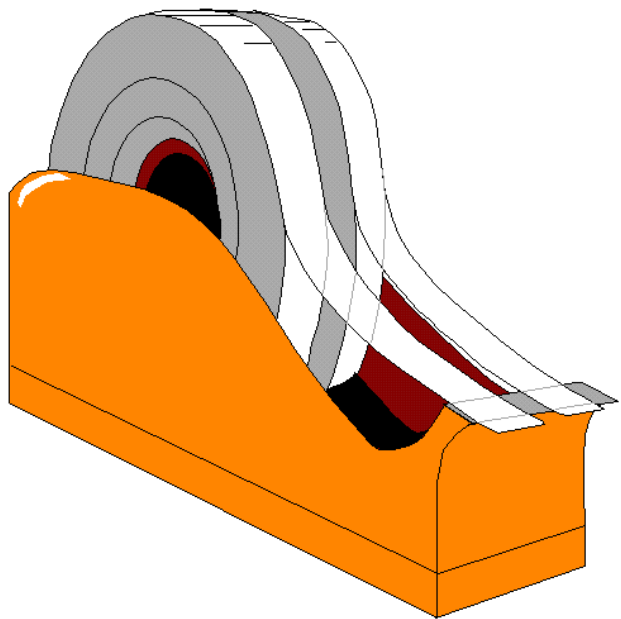

- La colla.
 - La carta.
 - Il nastro adesivo.

IL VOCABOLARIO

Far associare le singole parole all'immagine corrispondente.



- Guidare.
- Salire.
- Scendere.

IL VOCABOLARIO

Far associare le singole parole all'immagine corrispondente.



- Leggere.
- Giocare.
- Correre.

IL VOCABOLARIO

Far associare le singole parole all'immagine corrispondente.

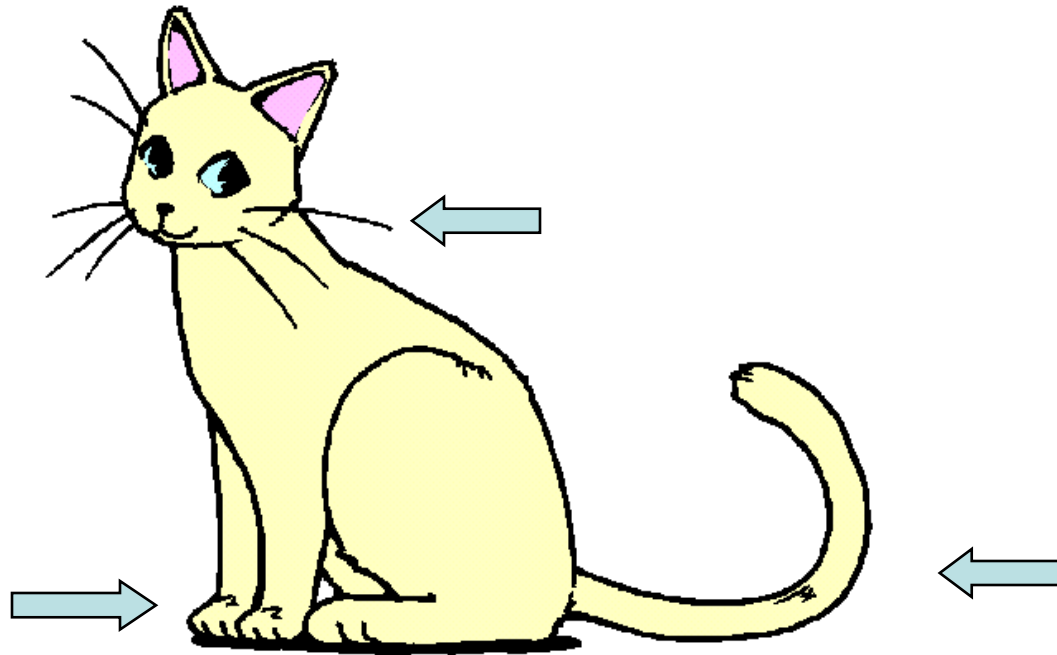

- La coda.
- I baffi.
- Le zampe.

IL VOCABOLARIO

Far associare le singole parole all'immagine corrispondente.

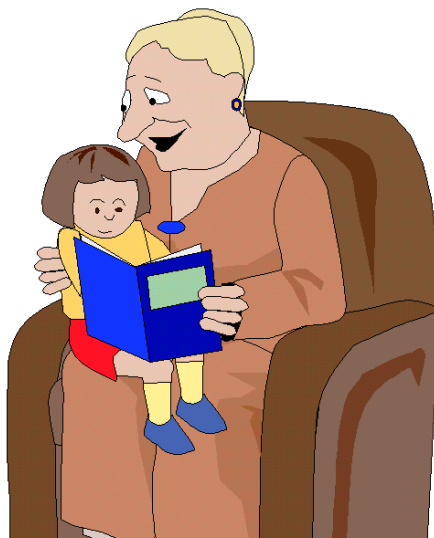

- Dondolarsi.
- Gustare.
- Raccontare.

IL VOCABOLARIO

Far associare le singole parole all'immagine corrispondente.



- Scivolare.
- Portare.
- Offrire.

IL VOCABOLARIO

Far associare le singole parole all'immagine corrispondente.

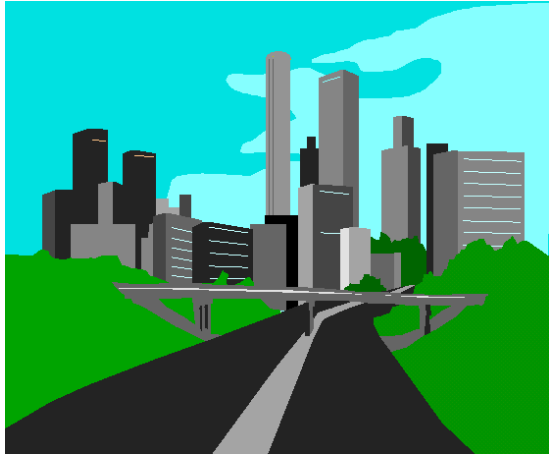

- La campagna.
- La città.
- La villa.

IL VOCABOLARIO

Far associare le singole parole all'immagine corrispondente.

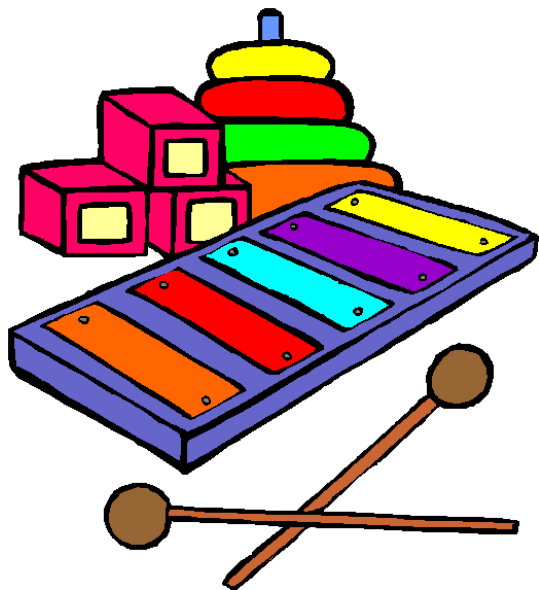

- La befana.
- I giocattoli.
- Il regalo.

IL VOCABOLARIO

Far associare le singole parole all'immagine corrispondente.

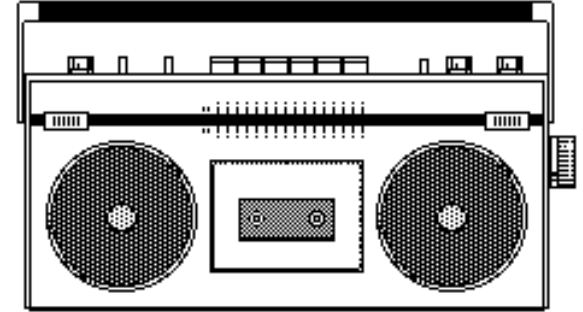
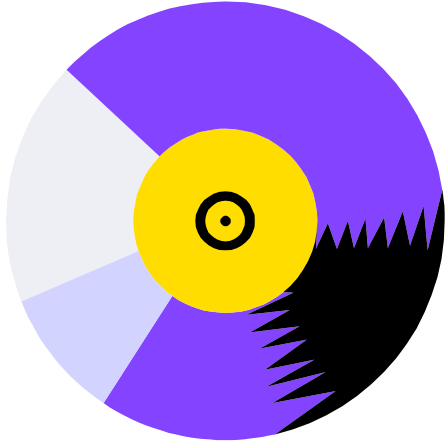

- La radio.
- Il disco.
- La cuffia.

IL VOCABOLARIO

Far associare le singole parole all'immagine corrispondente.

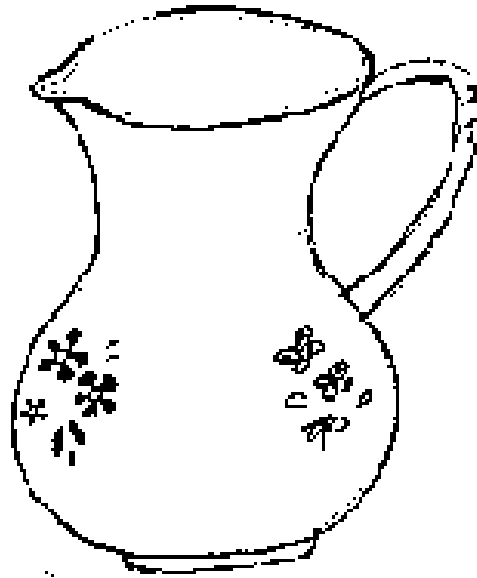
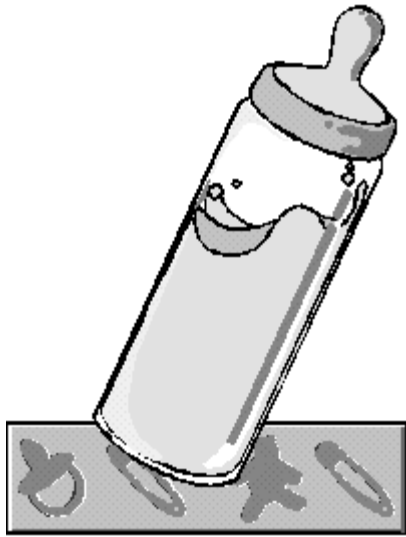

- La tazza.
- La brocca.
- Il biberon.

IL VOCABOLARIO

Far associare le singole parole all'immagine corrispondente.

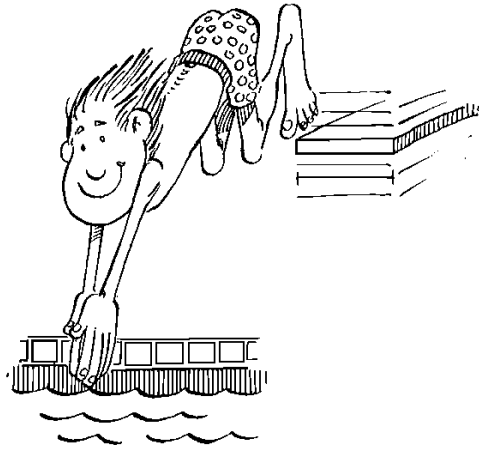

- Dormire
- Tuffarsi
- Sostenere.

IL VOCABOLARIO

Far associare le singole parole all'immagine corrispondente.



- Cadere.
- Scappare.
- Regalare.

IL VOCABOLARIO

Far associare le singole parole all'immagine corrispondente.



- Annaffiare.
- Pitturare.
- Pescare.

IL VOCABOLARIO

Far associare le singole parole all'immagine corrispondente.

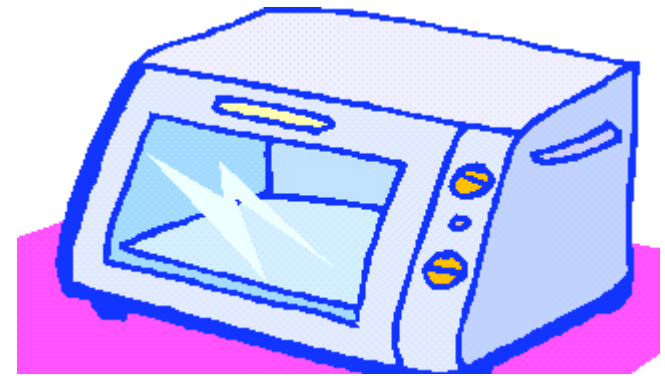
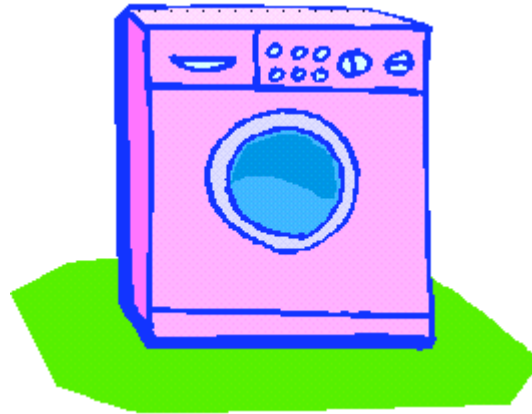

- Il ferro da stiro.
- Il forno.
- La lavatrice.

IL VOCABOLARIO

Far associare le singole parole all'immagine corrispondente.

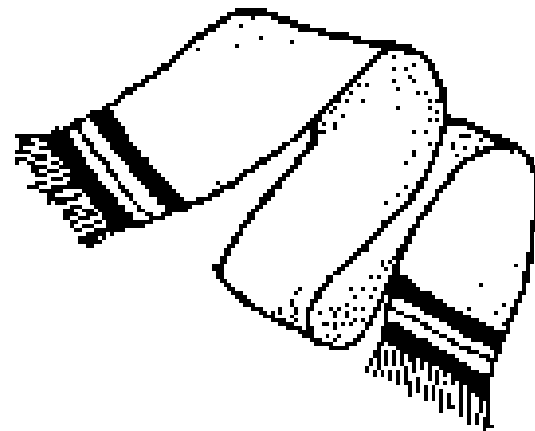
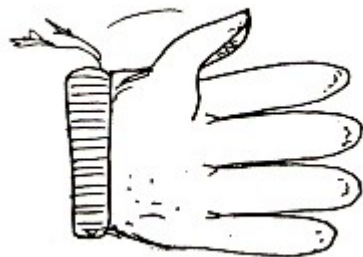

- I guanti.
- La sciarpa.
- Il cappello.

IL VOCABOLARIO

Far associare le singole parole all'immagine corrispondente.

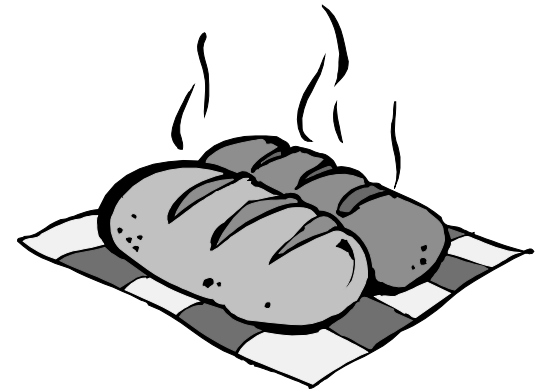
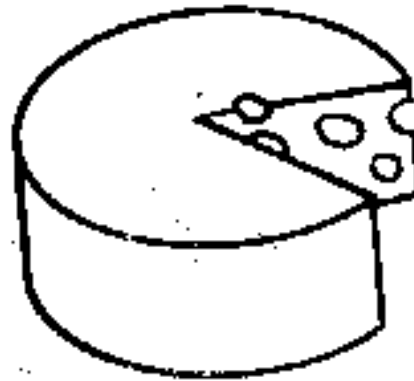
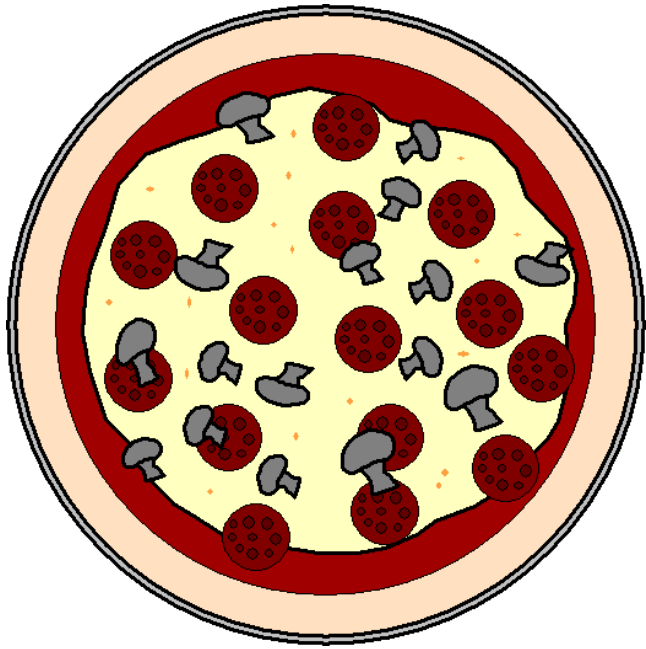

- Il pane.
- La pizza.
- Il formaggio.

IL VOCABOLARIO

Far associare le singole parole all'immagine corrispondente.

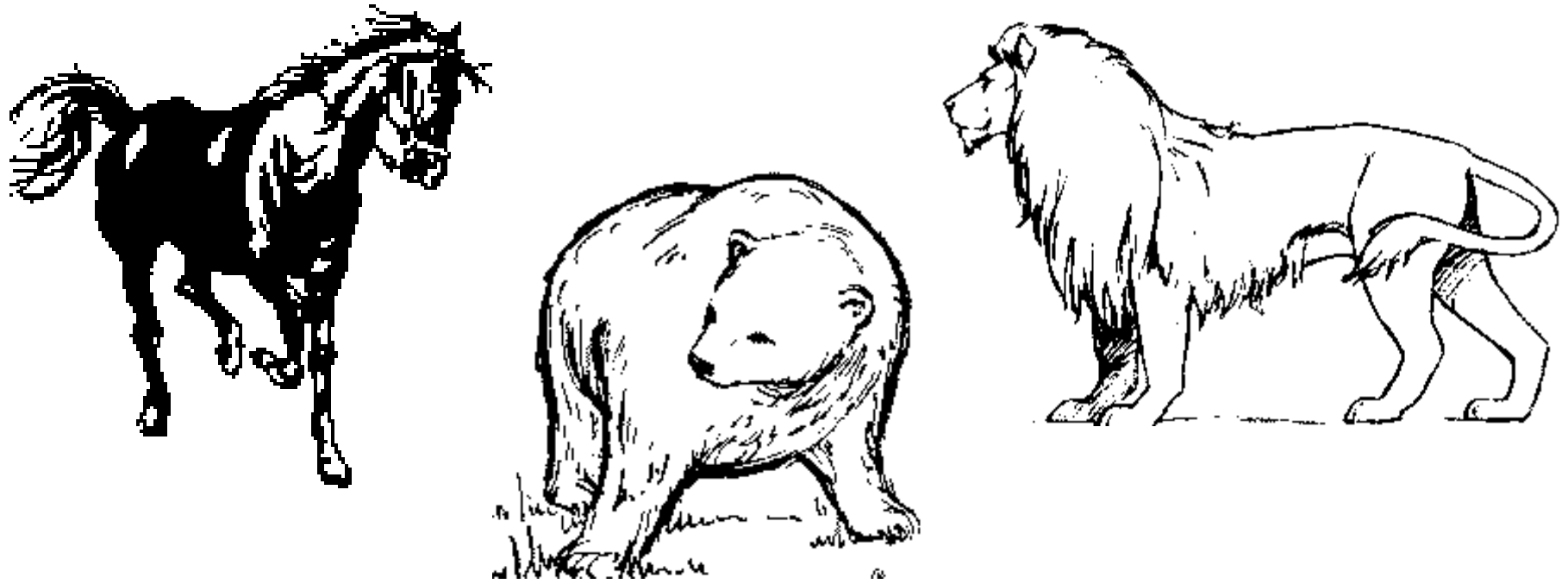

- L'orso.

- Il cavallo.

Il leone.

IL VOCABOLARIO

Far associare le singole parole all'immagine corrispondente.



- La colomba.
- L'angelo.
- Il cuore.

IL VOCABOLARIO

Far associare le singole parole all'immagine corrispondente.

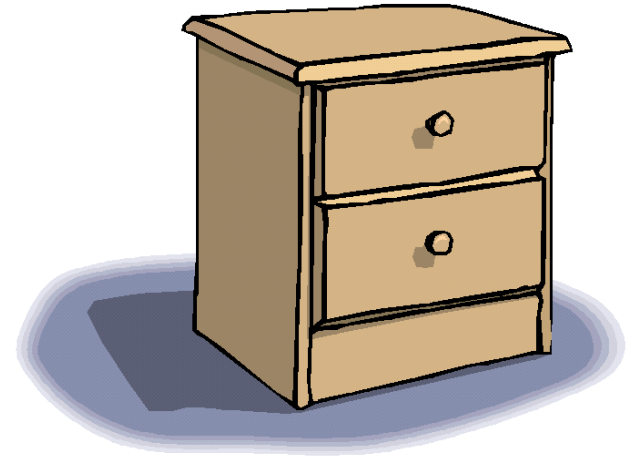
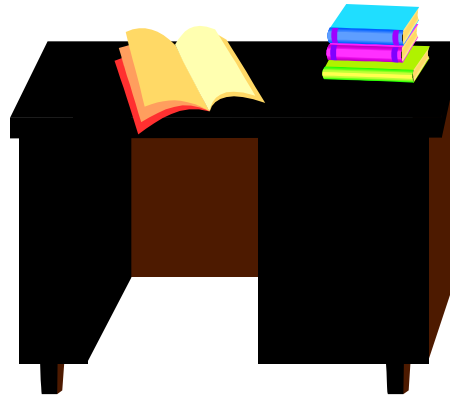
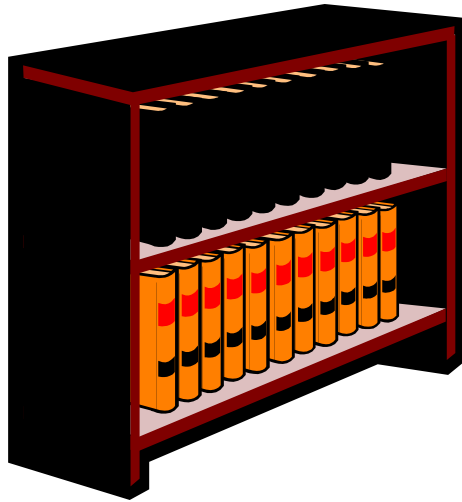

- La scrivania.
- Il comodino.
- La libreria.

IL VOCABOLARIO

Far associare le singole parole all'immagine corrispondente.

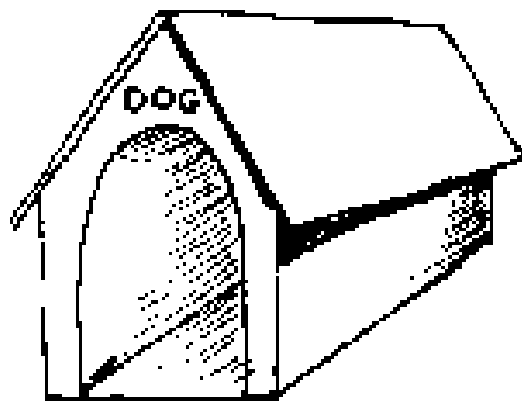
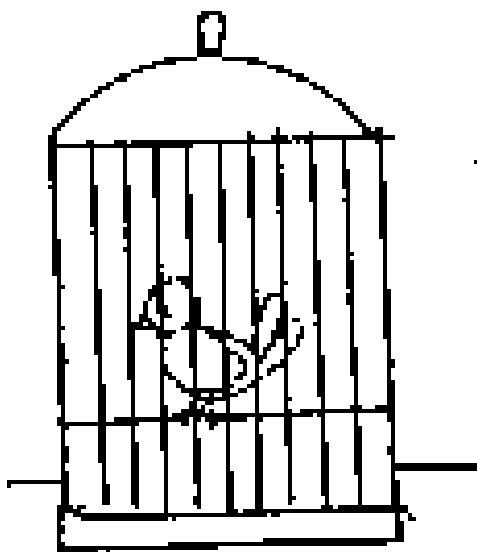

- Il nido.
- La gabbia.
- La cuccia.

IL VOCABOLARIO

Far associare le singole parole all'immagine corrispondente.

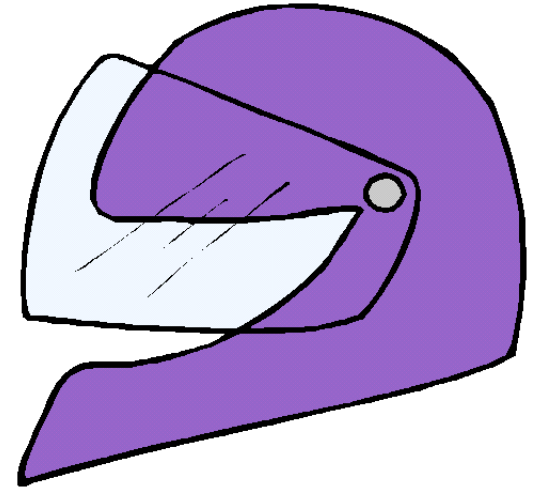

- Il casco.
- Il giaccone.
- L'ombrello.

IL VOCABOLARIO

Far associare le singole parole all'immagine corrispondente.

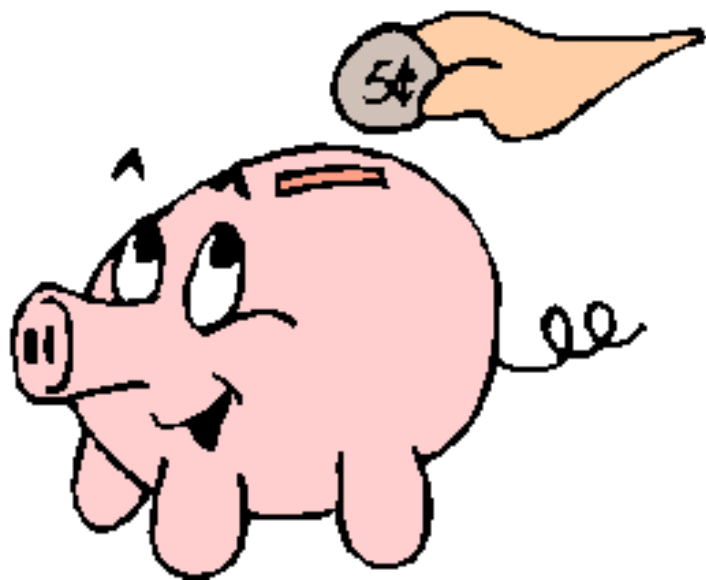

- Le monete.
 - La cassaforte.
 - Il salvadanaio.

IL VOCABOLARIO

Far associare le singole parole all'immagine corrispondente.

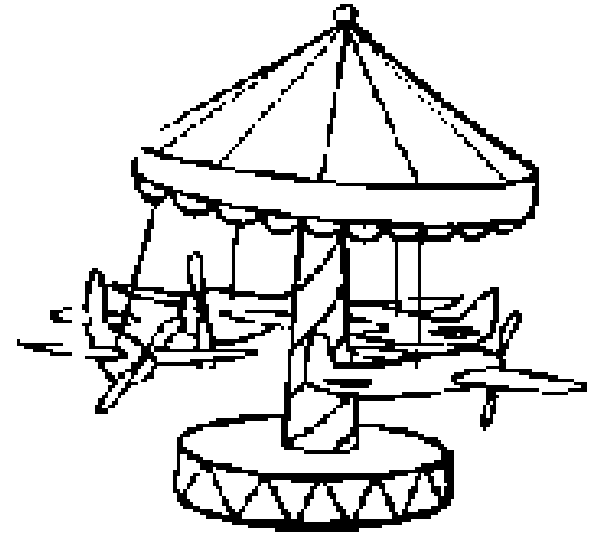
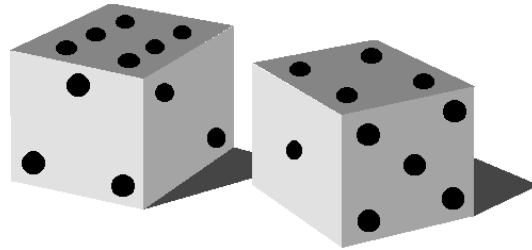
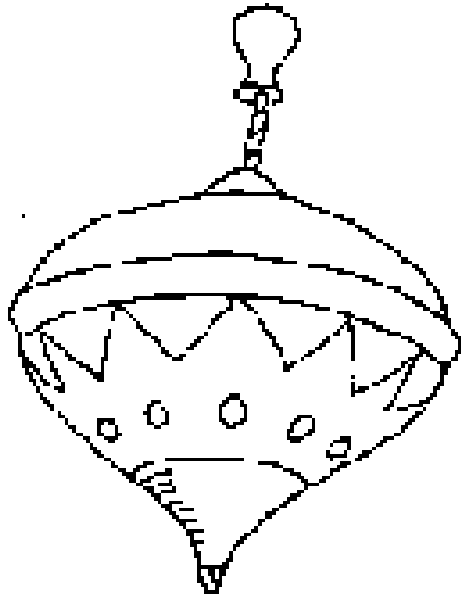

- La giostra.
- I dadi.
- La trottola.

IL VOCABOLARIO

Far associare le singole parole all'immagine corrispondente.

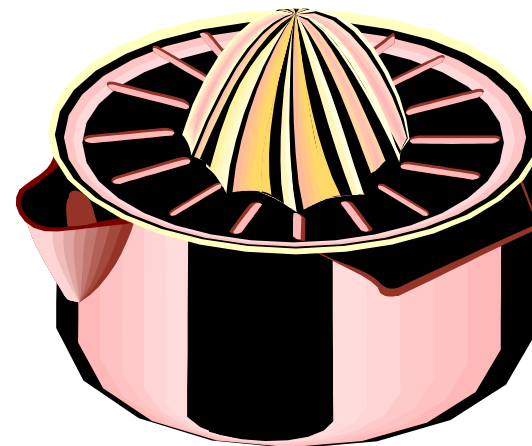
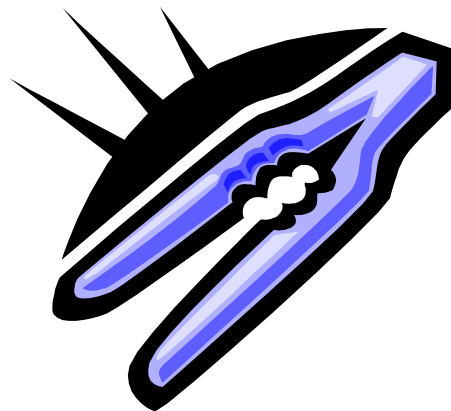

- Lo schiaccianoci.
- L'imbuto.
- Lo spremiagrumi.

IL VOCABOLARIO

Far associare le singole parole all'immagine corrispondente.



- Aiutare.
- Parlare.
- Ascoltare.

IL VOCABOLARIO

Far associare le singole parole all'immagine corrispondente.

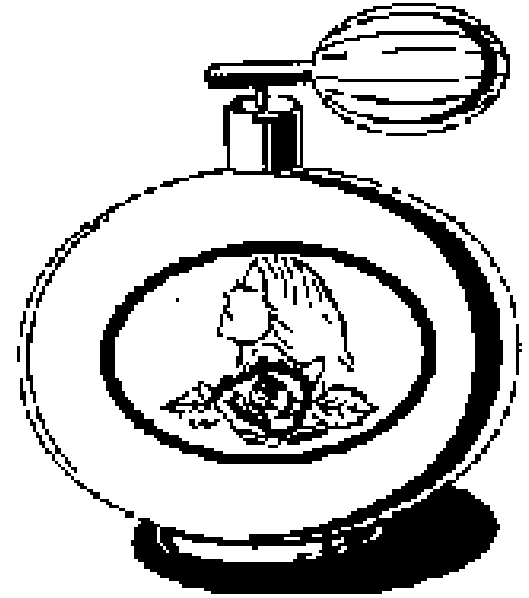
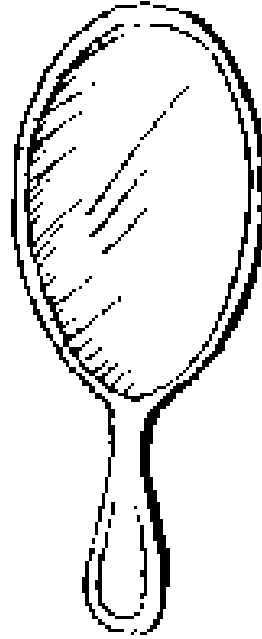

- Il profumo.
- Il pettine.
- Lo specchio.

IL VOCABOLARIO

Far associare le singole parole all'immagine corrispondente.

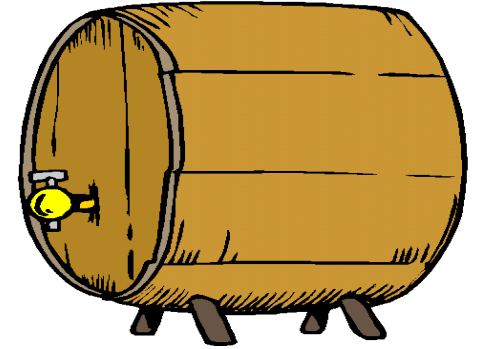
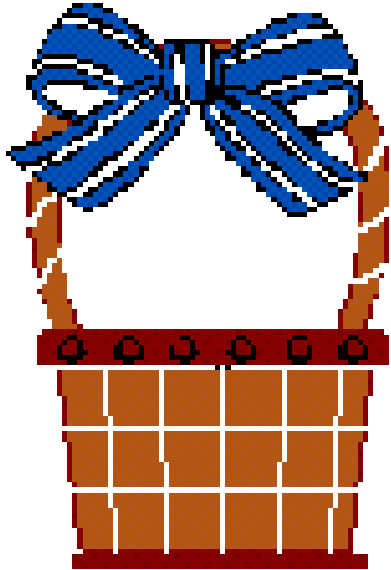

- Il cestino.
- La botte.
- Il vaso.

IL VOCABOLARIO

Far associare le singole parole all'immagine corrispondente.

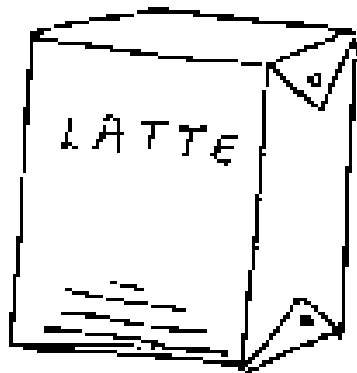

- I biscotti.
- Il latte.
- Il caffè.

IL VOCABOLARIO

Far associare le singole parole all'immagine corrispondente.

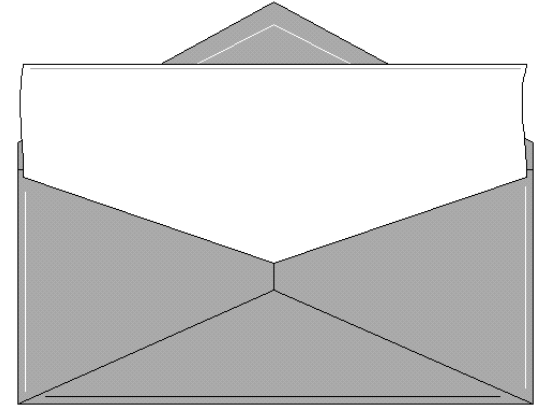
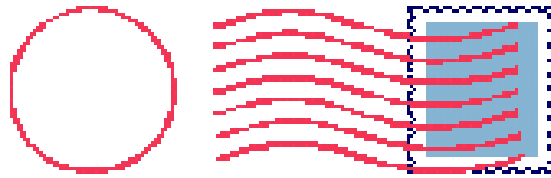
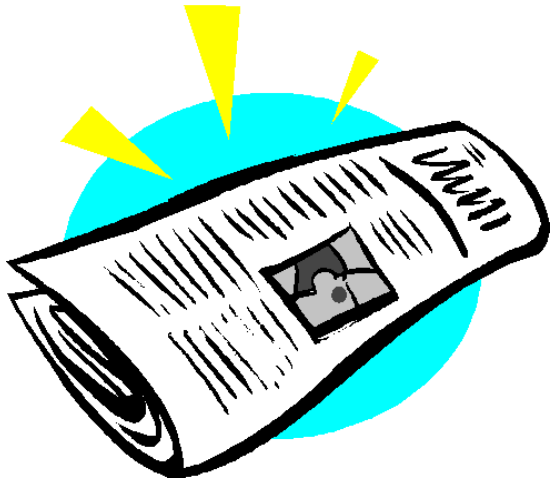

- Il giornale.
- Il timbro.
- La busta.

IL VOCABOLARIO

Far associare le singole parole all'immagine corrispondente.

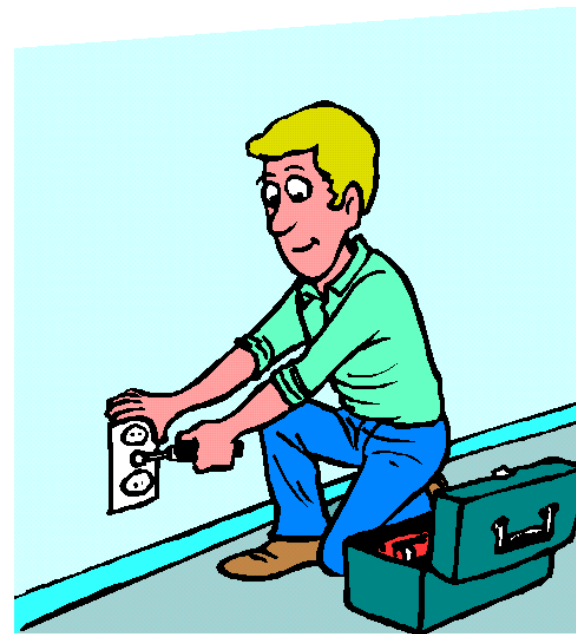

- Il poliziotto.
- L'elettricista.
- L'imbianchino.

IL VOCABOLARIO

Far associare le singole parole all'immagine corrispondente.

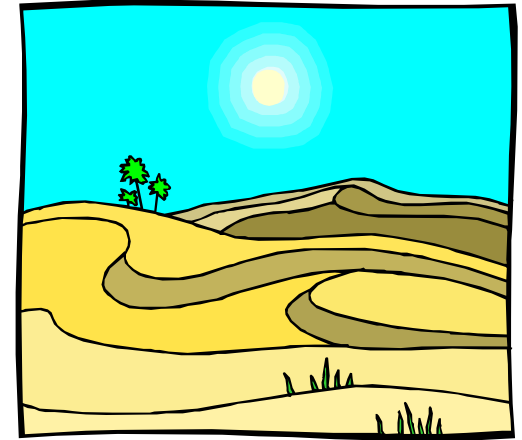
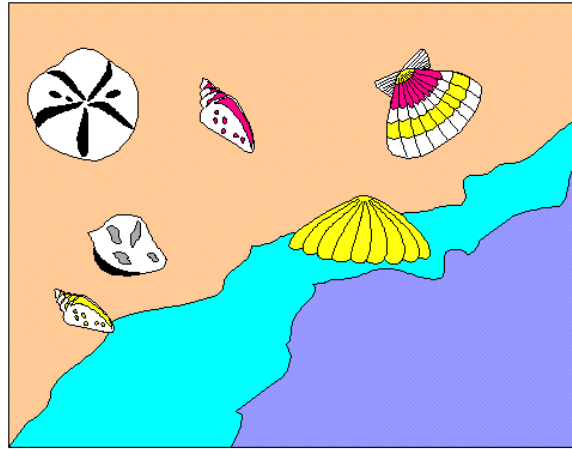

- Il giorno.
- La notte.
- La spiaggia.

IL VOCABOLARIO

Far associare le singole parole all'immagine corrispondente.

“ VOGLIA DI CRESCERE ”

PROGRAMMA BASE PER LO SVILUPPO LOGICO E COGNITIVO

ASSOCIAZIONI DI IMMAGINI UGUALI O SIMILI

Associa le singole parole all'immagine corrispondente.

ASSOCIAZIONI DI IMMAGINI UGUALI

La possibilità di stimolazione logica fino ai tre anni, in pratica coincide per lo più con la possibilità dello sviluppo psicomotorio, percettivo e del linguaggio.

Il bambino, infatti, manifesta le sue capacità logiche attraverso un'attività rivolta soprattutto all'analisi, confronto e interpretazione della realtà sensoriale.

Nella sua esplorazione del mondo vengono ad essere coinvolti tutti i sensi per cui è importante una molteplicità di stimolazioni.

Maggiore attenzione noi diamo alla percezione uditiva e visiva, in quanto è più facile, per gli studiosi e per gli educatori in genere, preparare e somministrare materiale graduato e opportunamente variato composto da immagini, da suoni e parole, piuttosto che da gusti e da odori.

Le schede che qui presentiamo sono formate da immagini uguali o simili da riconoscere e da associare che hanno lo scopo di sviluppare nel bambino non solo la percezione visiva ma anche il linguaggio, i primi processi di astrazione e i fondamentali rapporti spaziali.

Il bambino viene inoltre arricchito da numerosi elementi culturali.

In tali schede sono presenti delle immagini nella parte alta da associare con quelle corrispondenti nella parte bassa.

UTILIZZAZIONE

Per un corretto uso di tali schede è opportuno seguire due fasi:

I fase

Inizialmente l'educatore dirà il nome dell'immagine di cui chiede l'associazione, ed è sufficiente in questa prima frase che il bambino risponda con un semplice gesto della mano.

Nel caso di bambini molto piccoli o inibiti l'educatore potrà tenere con la sua la mano del bambino in modo tale da incoraggiarlo e avviarlo al gioco associativo.

II fase

Gradualmente sarà il bambino stesso a verbalizzare il nome delle immagini più semplici mentre effettuerà l'associazione.

ETA' MENTALE DI RIFERIMENTO

Tre anni.

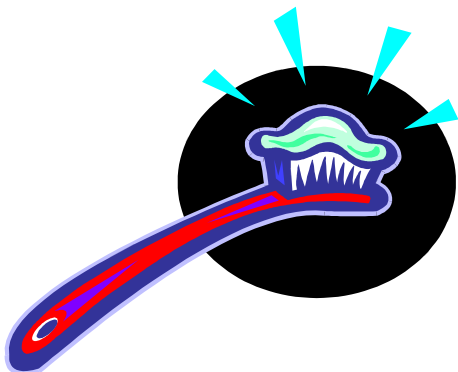
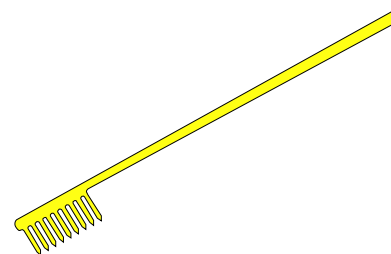
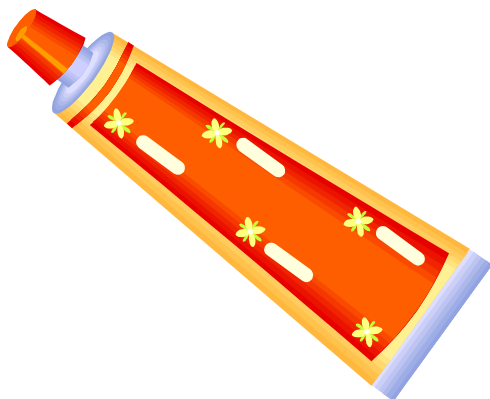

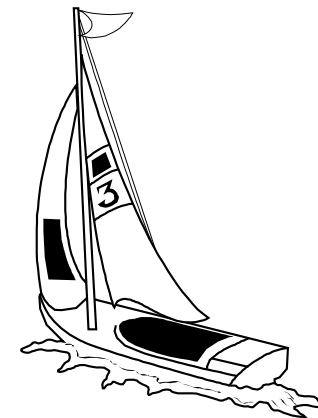
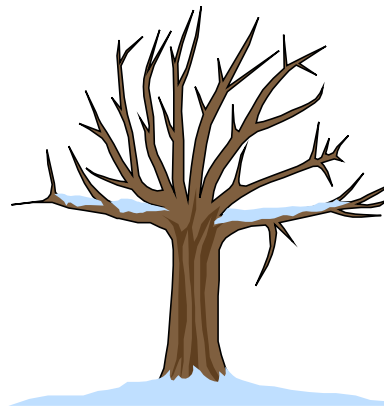
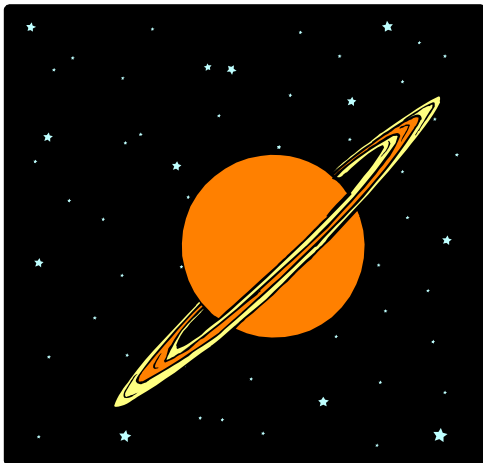
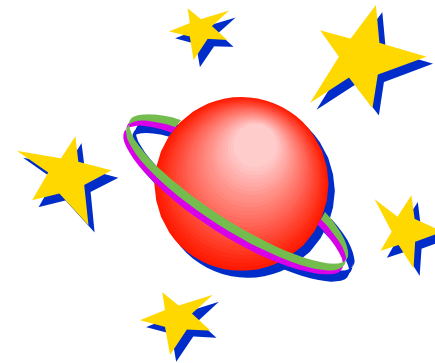
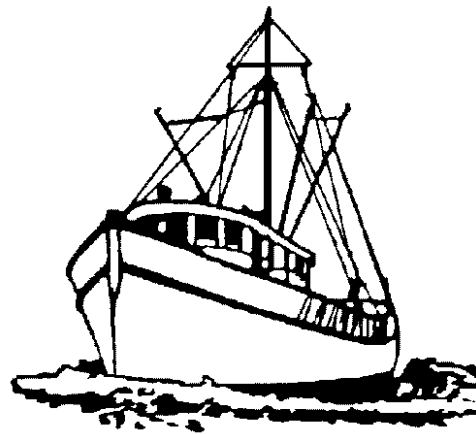

ASSOCIAZIONI DI IMMAGINI UGUALI O SIMILI
Associare le immagini uguali o simili.

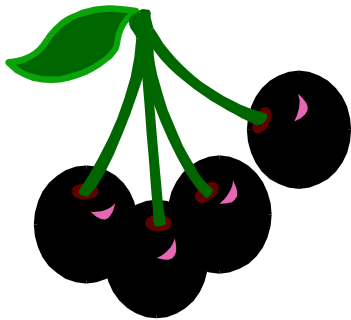
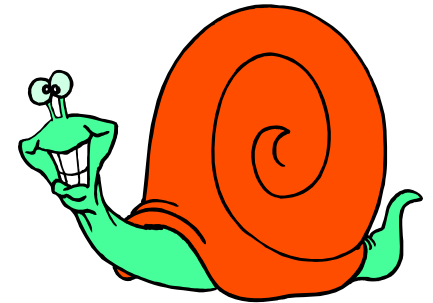

ASSOCIAZIONI DI IMMAGINI UGUALI O SIMILI
Associare le immagini uguali o simili.

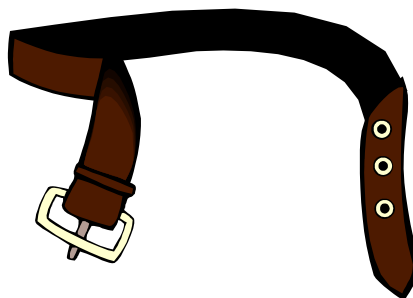
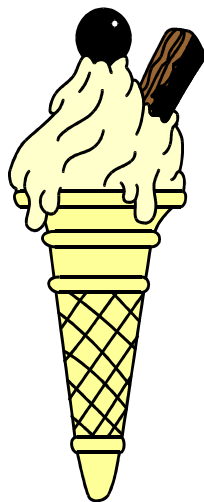
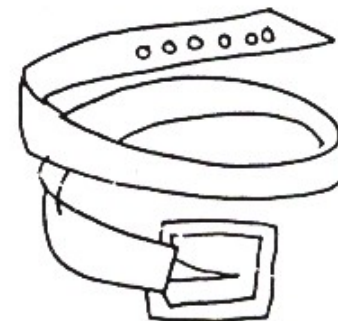
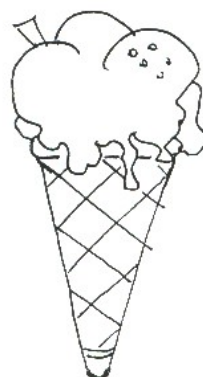
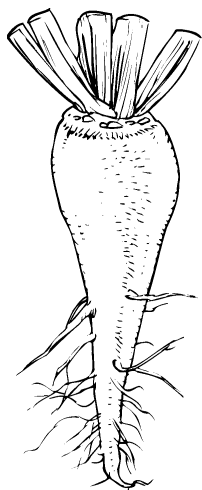

ASSOCIAZIONI DI IMMAGINI UGUALI O SIMILI
Associare le immagini uguali o simili.

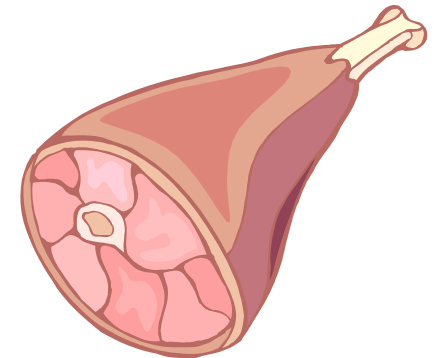
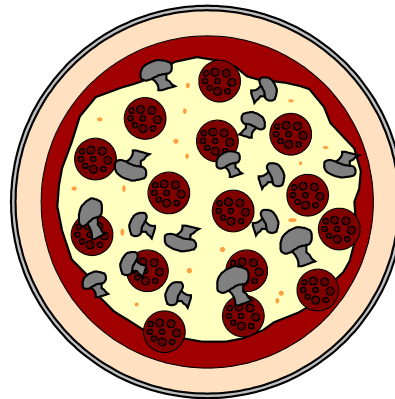
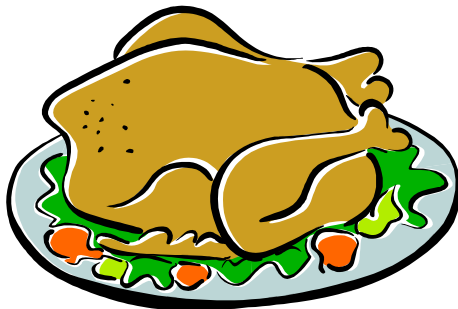
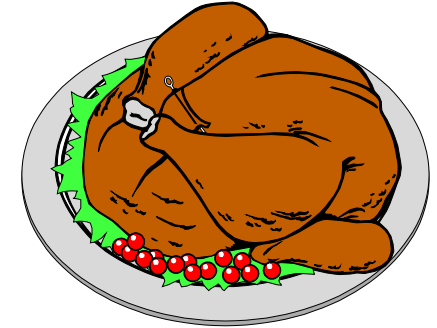
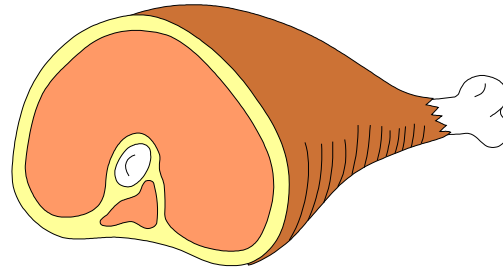
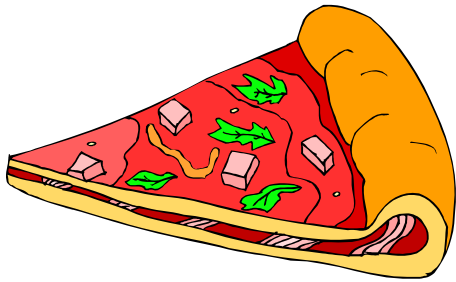

ASSOCIAZIONI DI IMMAGINI UGUALI O SIMILI
Associare le immagini uguali o simili.

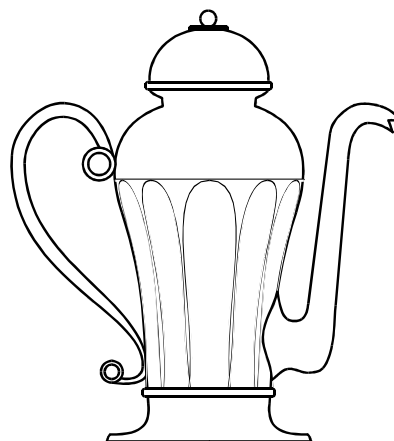
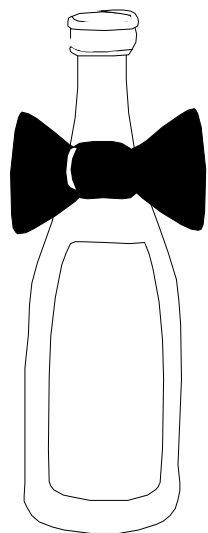
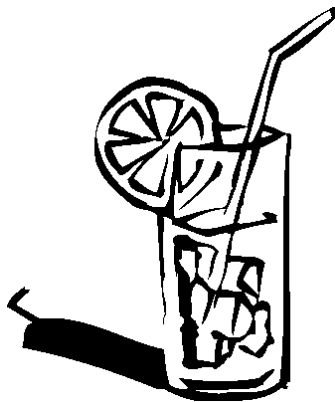
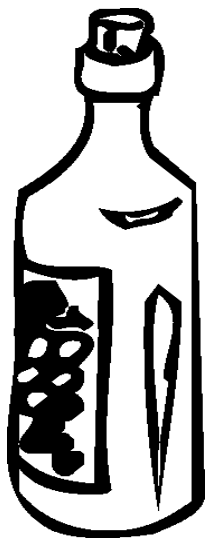

ASSOCIAZIONI DI IMMAGINI UGUALI O SIMILI
Associare le immagini uguali o simili.

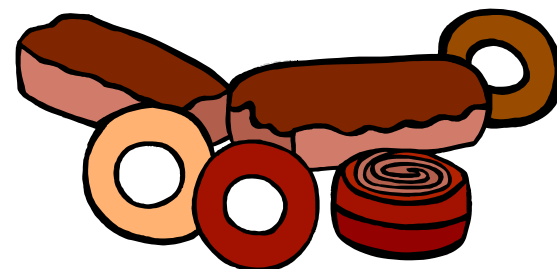
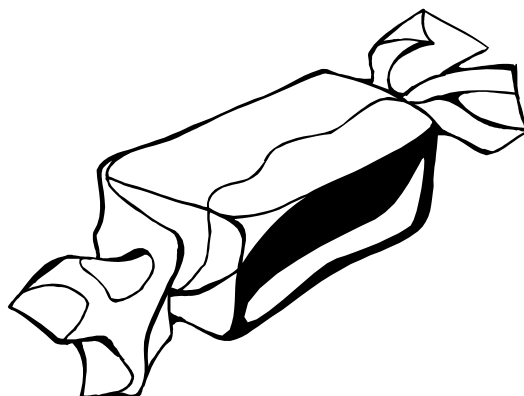
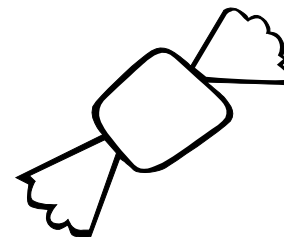
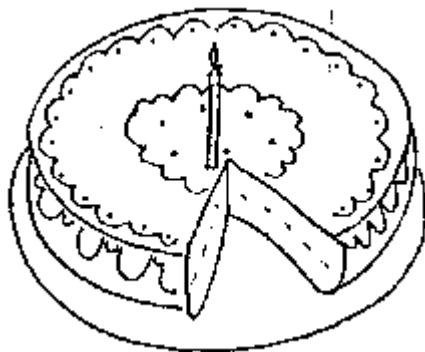
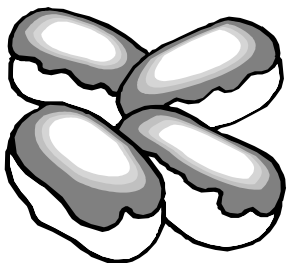

ASSOCIAZIONI DI IMMAGINI UGUALI O SIMILI
Associare le immagini uguali o simili.

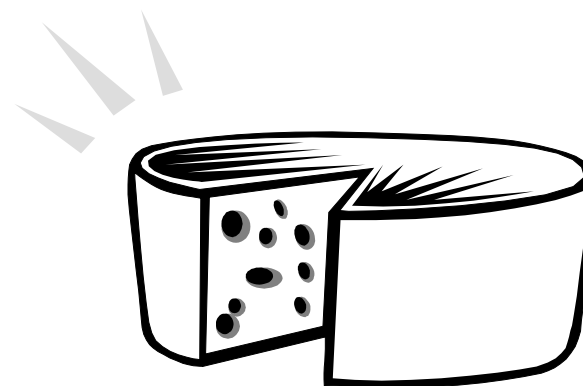
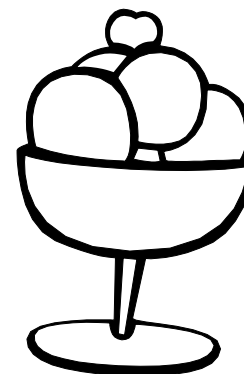
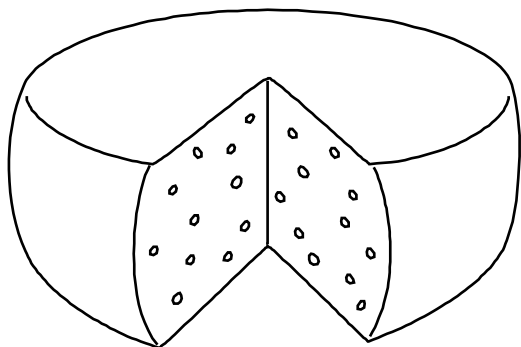

ASSOCIAZIONI DI IMMAGINI UGUALI O SIMILI
Associare le immagini uguali o simili.

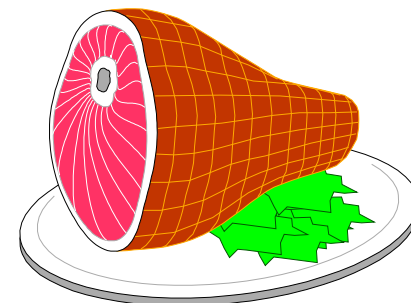
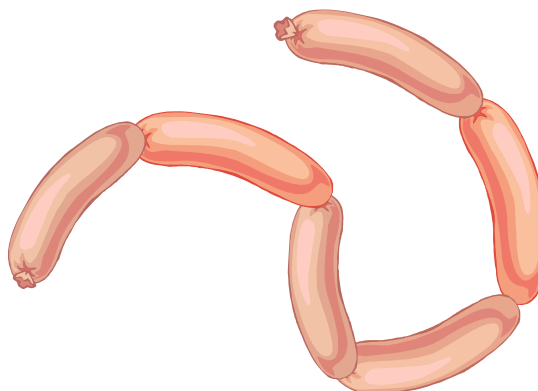
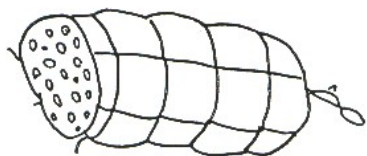
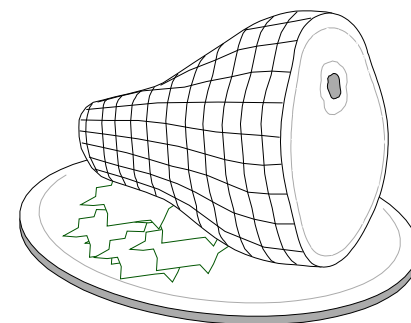
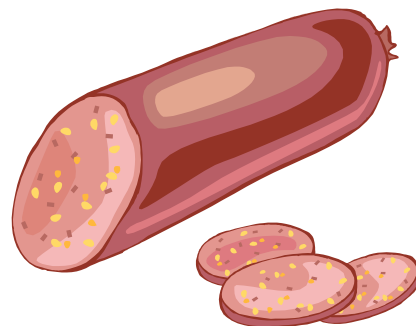
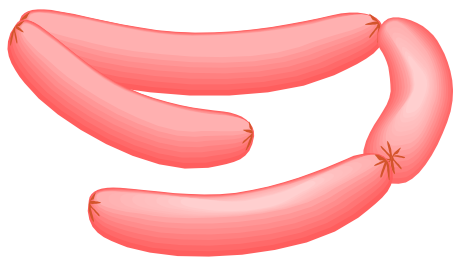

ASSOCIAZIONI DI IMMAGINI UGUALI O SIMILI
Associare le immagini uguali o simili.

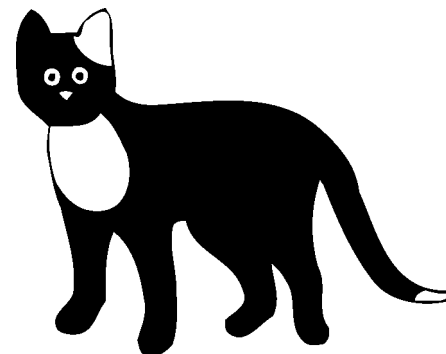
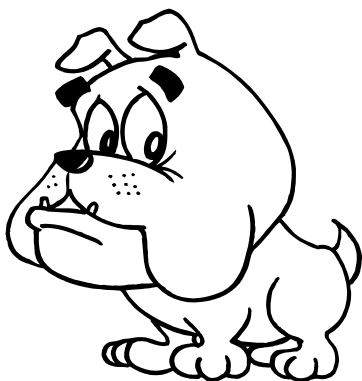
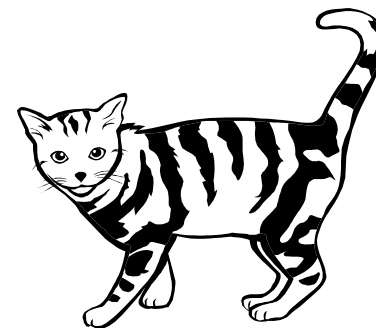
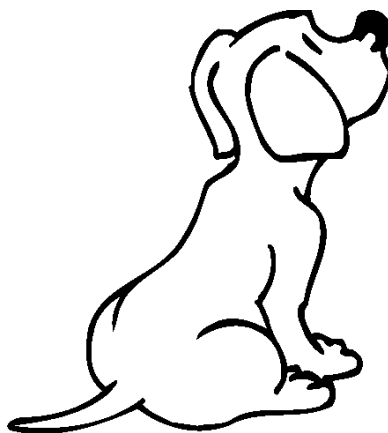

ASSOCIAZIONI DI IMMAGINI UGUALI O SIMILI
Associare le immagini uguali o simili.

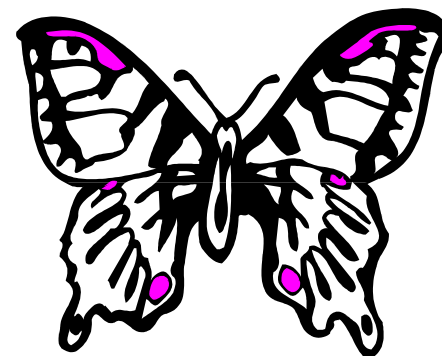
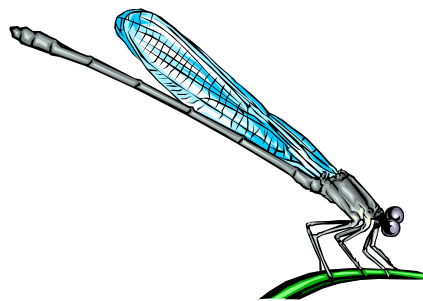
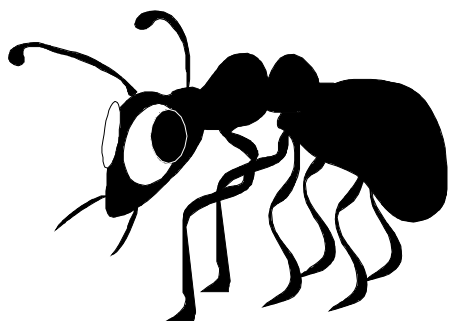
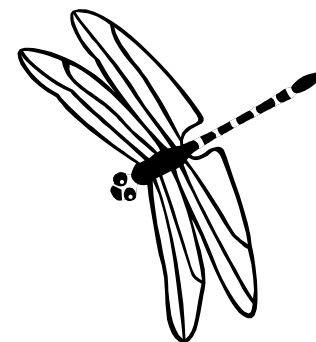
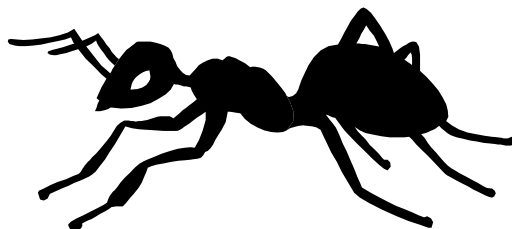
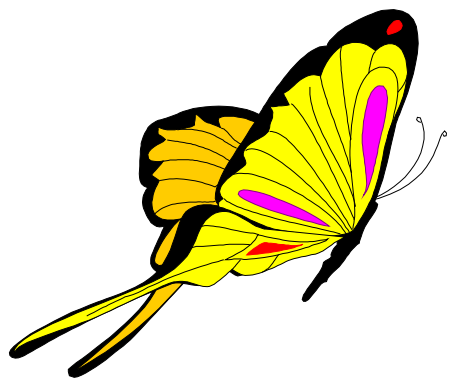

ASSOCIAZIONI DI IMMAGINI UGUALI O SIMILI
Associare le immagini uguali o simili.

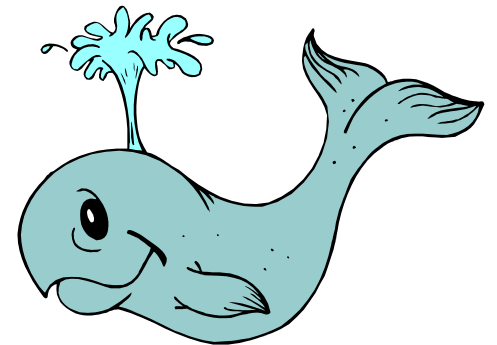
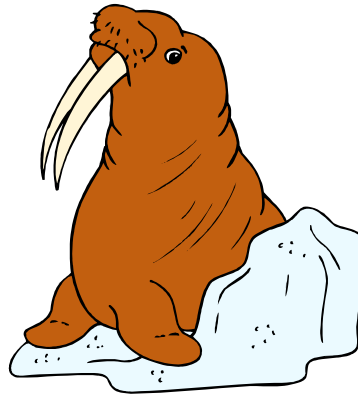
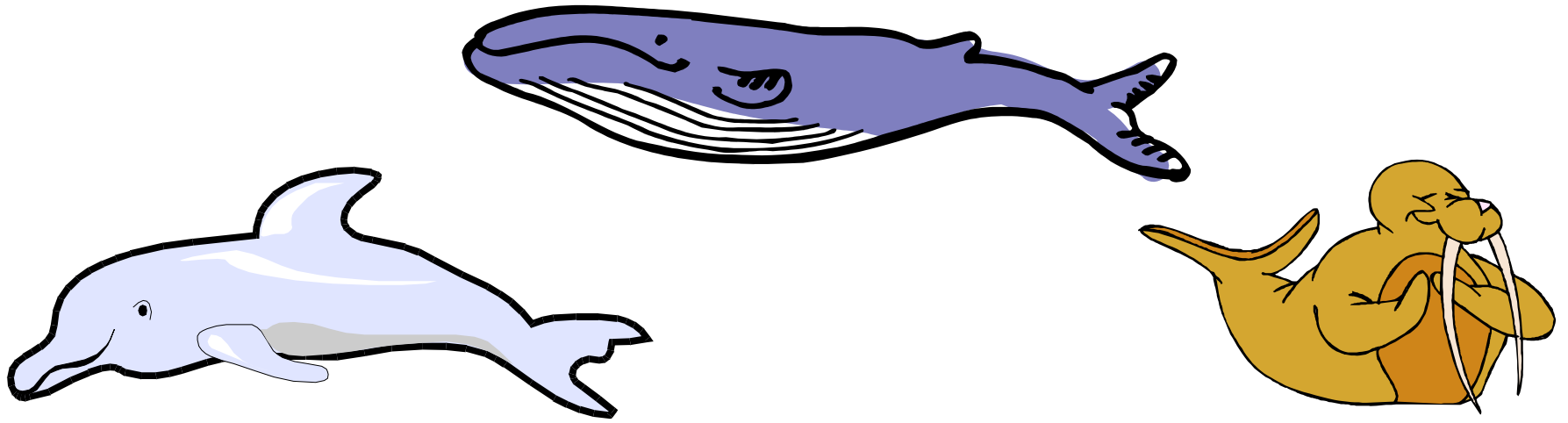

ASSOCIAZIONI DI IMMAGINI UGUALI O SIMILI
Associare le immagini uguali o simili.

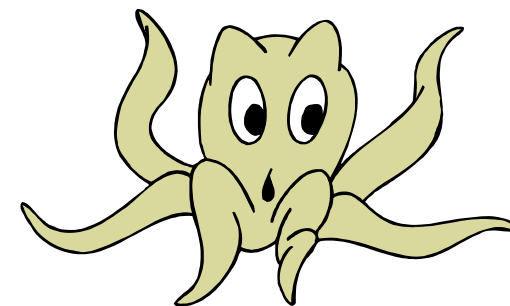
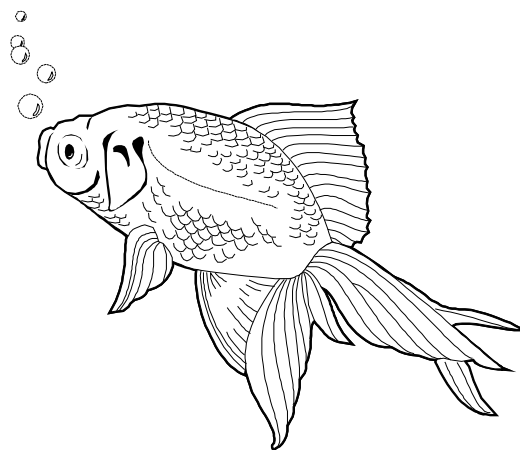
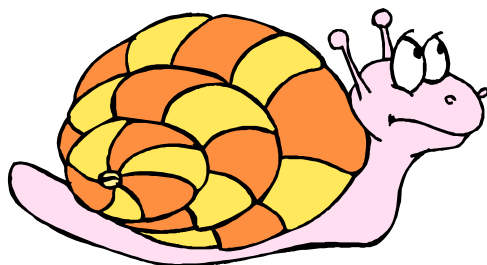
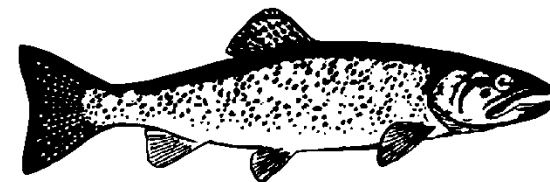
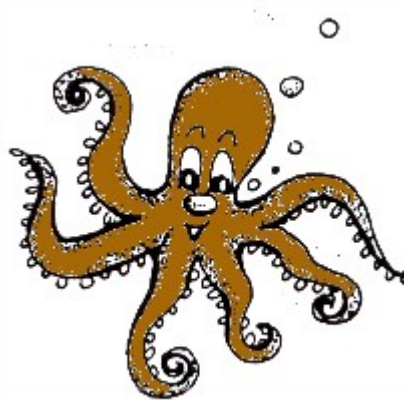

ASSOCIAZIONI DI IMMAGINI UGUALI O SIMILI
Associare le immagini uguali o simili.

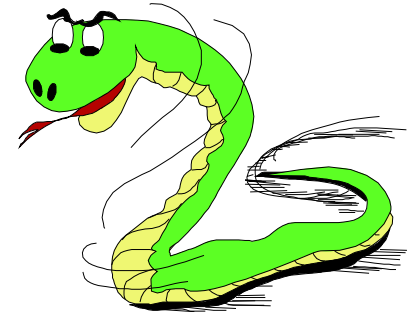
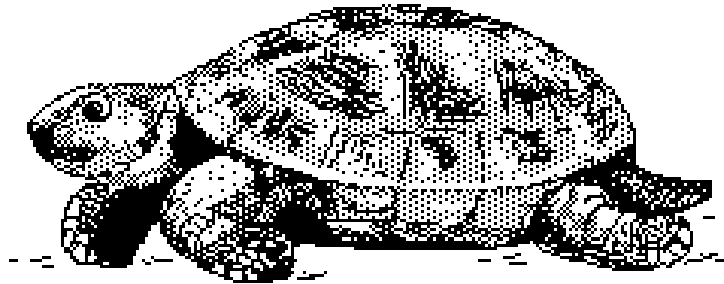
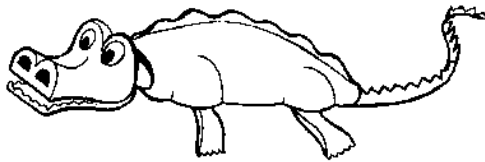
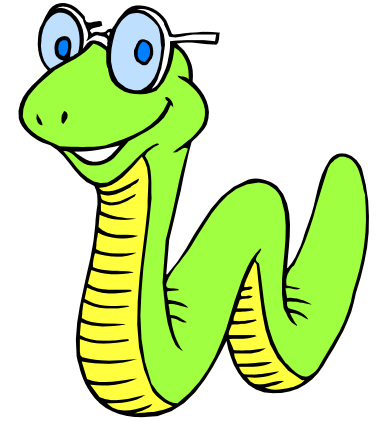
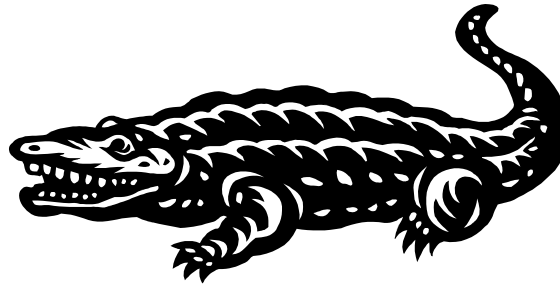
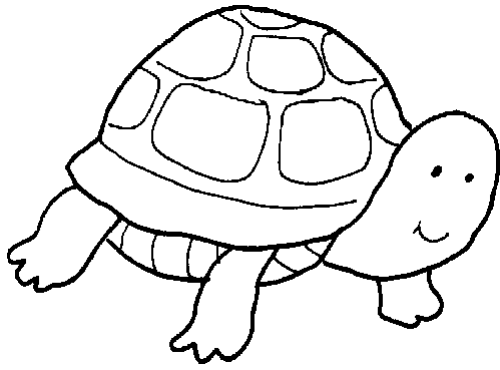

ASSOCIAZIONI DI IMMAGINI UGUALI O SIMILI
Associare le immagini uguali o simili.

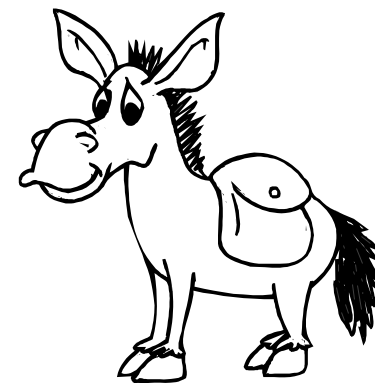
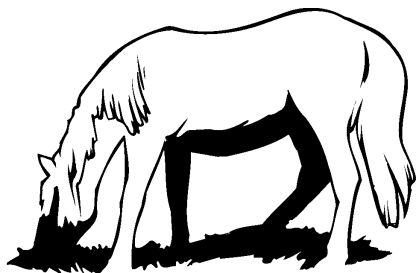
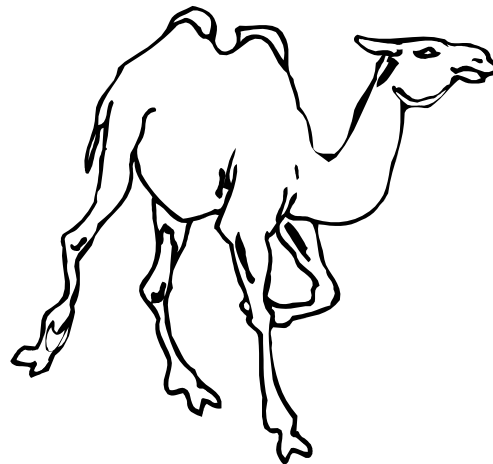
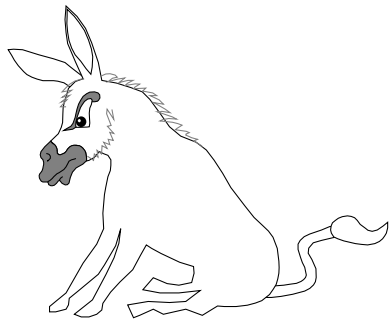

ASSOCIAZIONI DI IMMAGINI UGUALI O SIMILI
Associare le immagini uguali o simili.

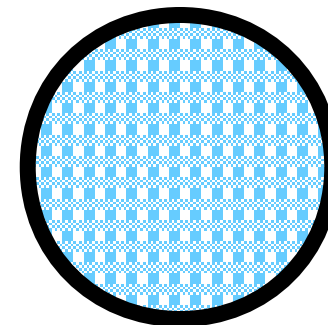
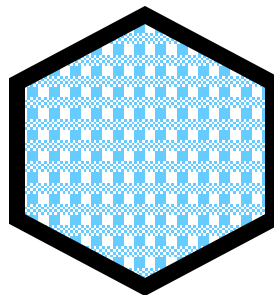
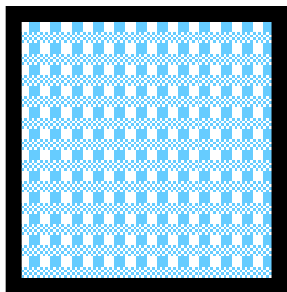
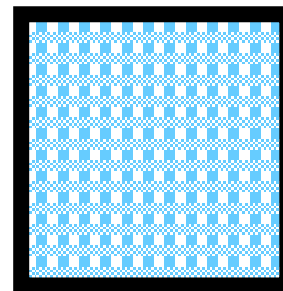
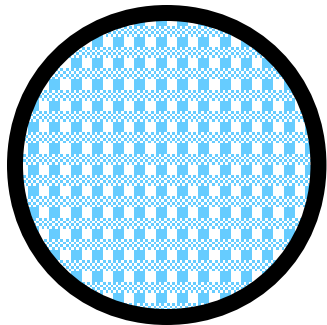

ASSOCIAZIONI DI IMMAGINI UGUALI O SIMILI
Associare le immagini uguali o simili.

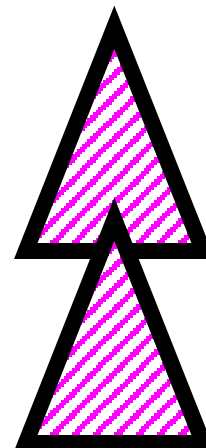
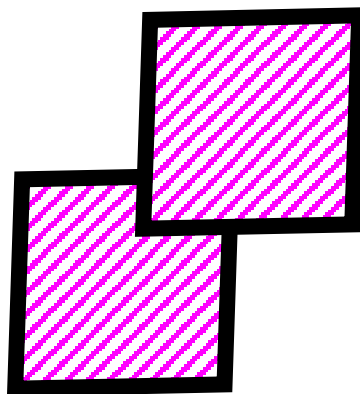
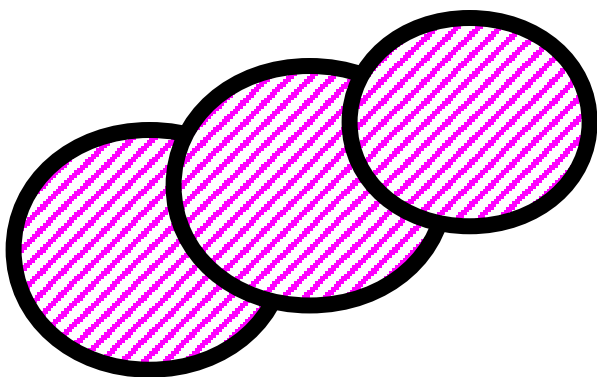
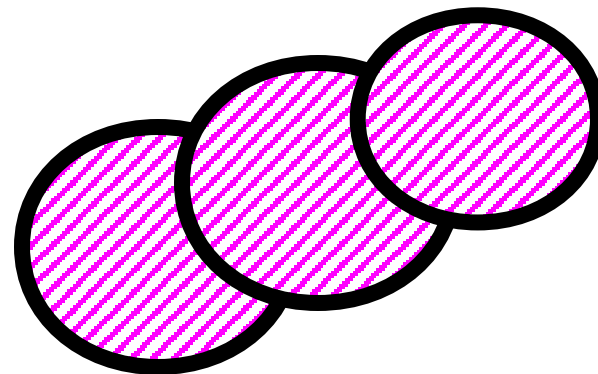
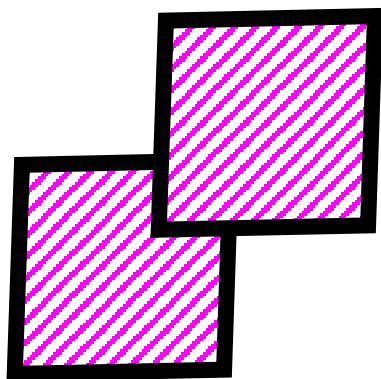

ASSOCIAZIONI DI IMMAGINI UGUALI O SIMILI
Associare le immagini uguali o simili.

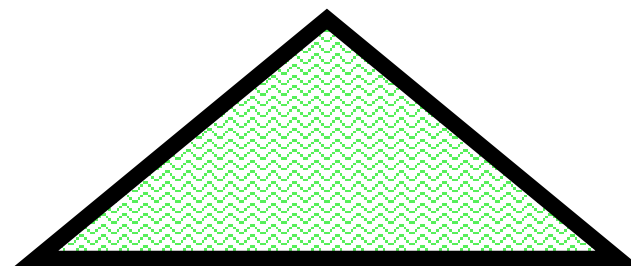
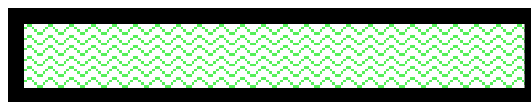
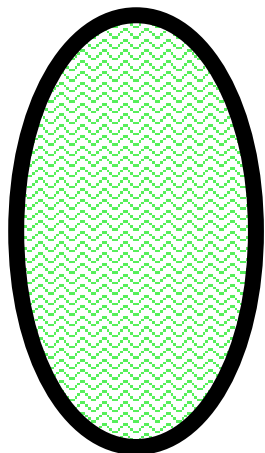
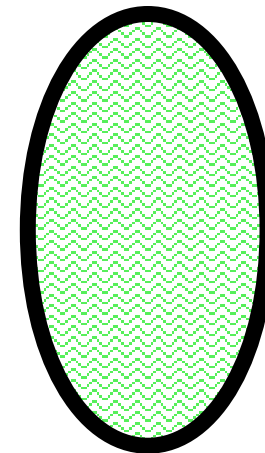
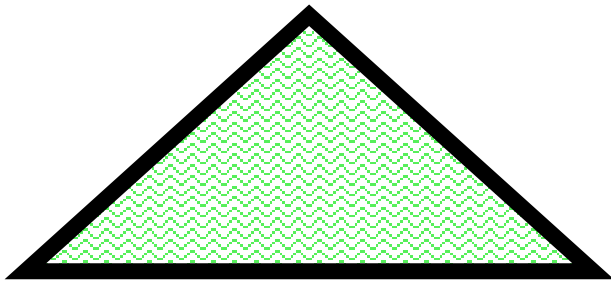

ASSOCIAZIONI DI IMMAGINI UGUALI O SIMILI
Associare le immagini uguali o simili.

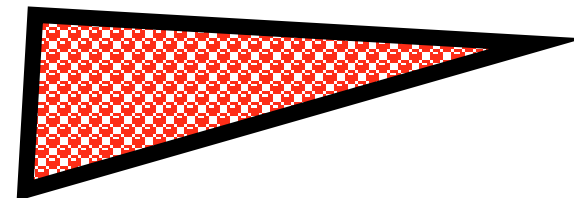
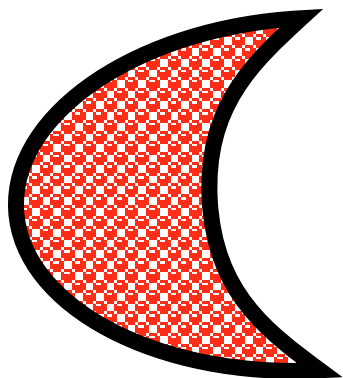
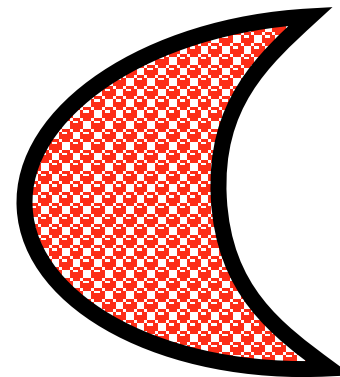
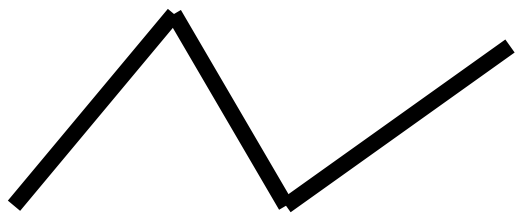

ASSOCIAZIONI DI IMMAGINI UGUALI O SIMILI
Associare le immagini uguali o simili.

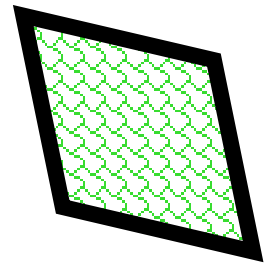
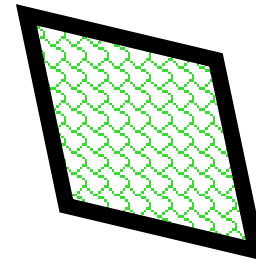
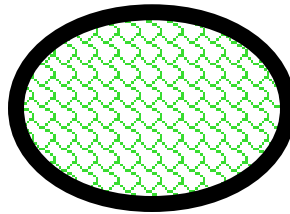
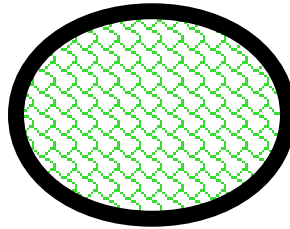
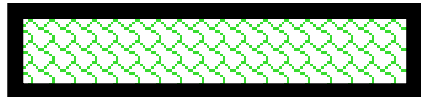
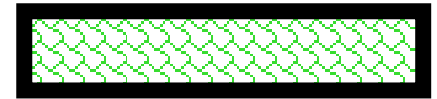
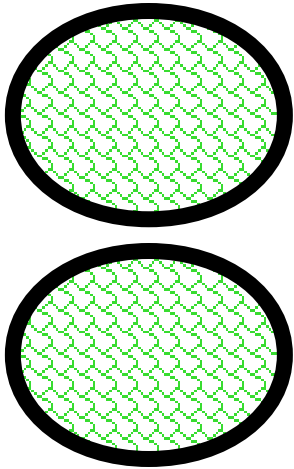

ASSOCIAZIONI DI IMMAGINI UGUALI O SIMILI
Associare le immagini uguali o simili.

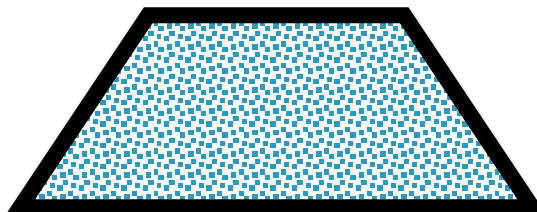
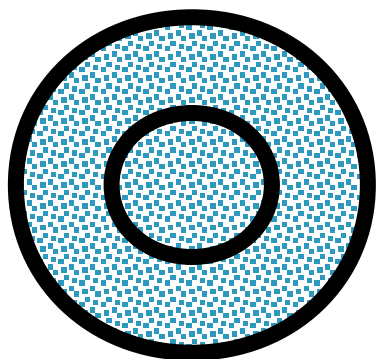
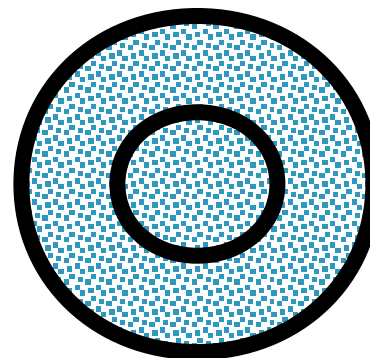

ASSOCIAZIONI DI IMMAGINI UGUALI O SIMILI
Associare le immagini uguali o simili.

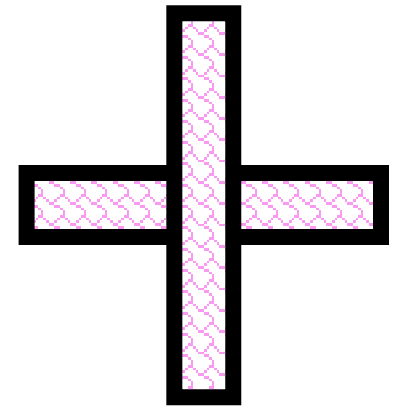
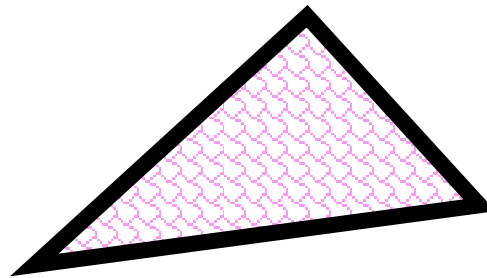
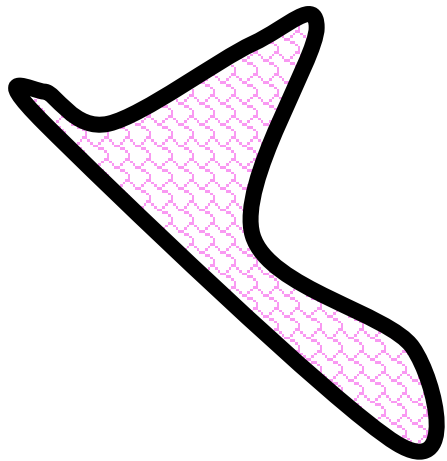
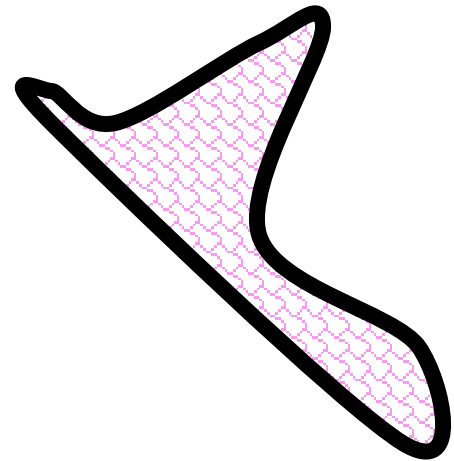
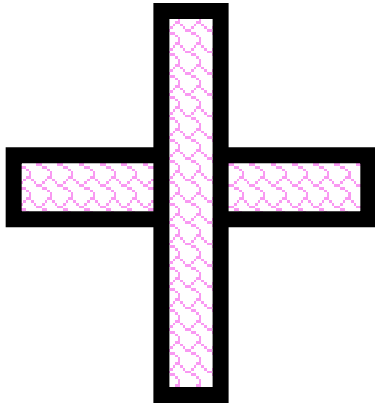

ASSOCIAZIONI DI IMMAGINI UGUALI O SIMILI
Associare le immagini uguali o simili.

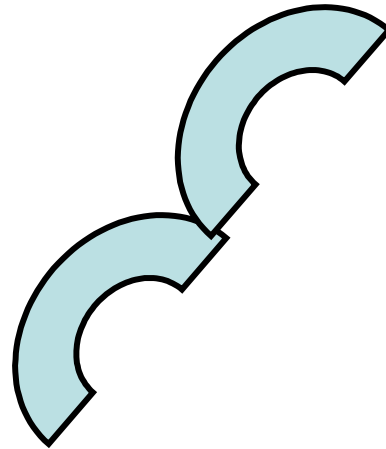

ASSOCIAZIONI DI IMMAGINI UGUALI O SIMILI
Associare le immagini uguali o simili.

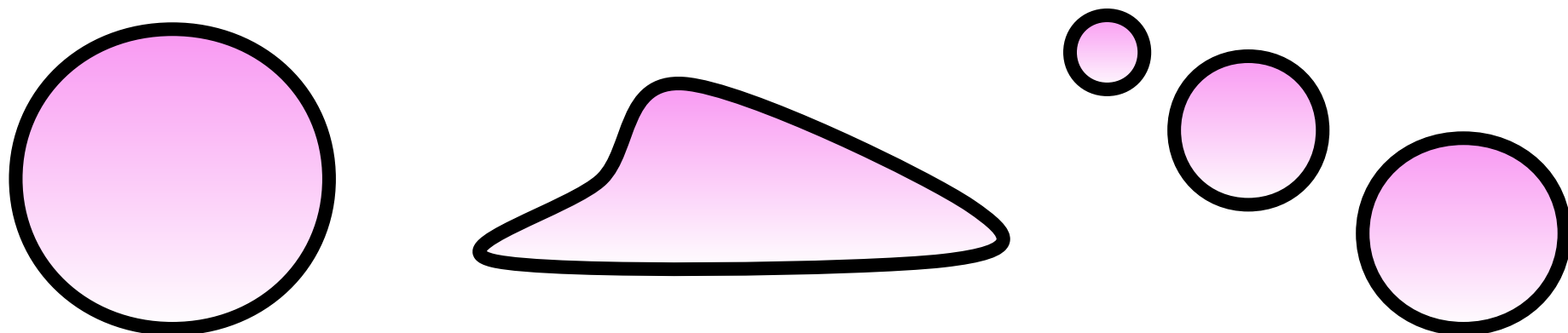

ASSOCIAZIONI DI IMMAGINI UGUALI O SIMILI
Associare le immagini uguali o simili.

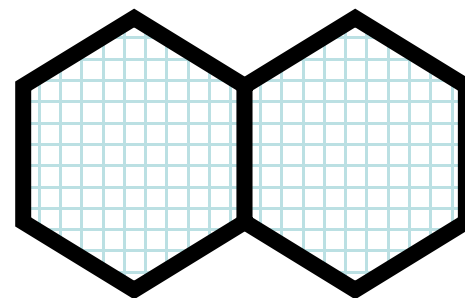
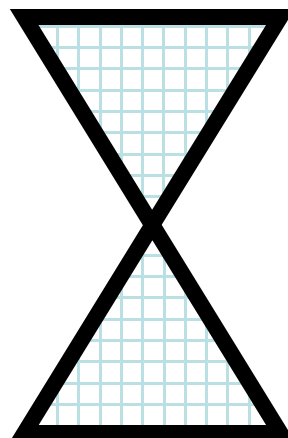
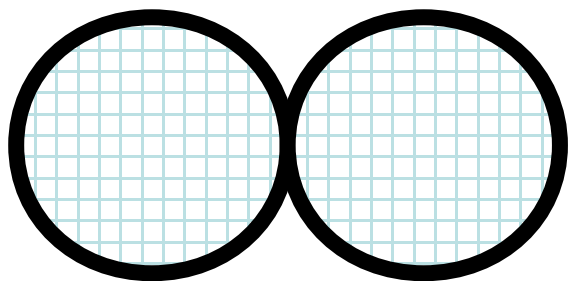
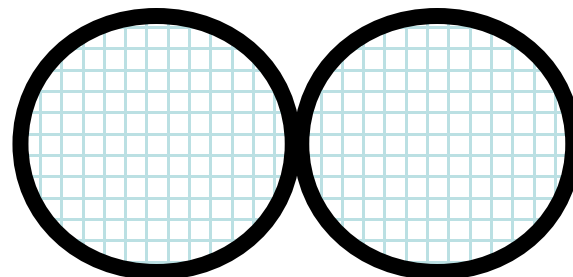
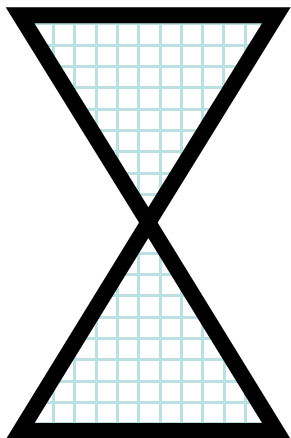

ASSOCIAZIONI DI IMMAGINI UGUALI O SIMILI
Associare le immagini uguali o simili.

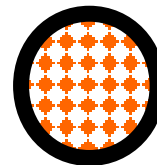
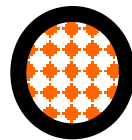
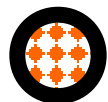
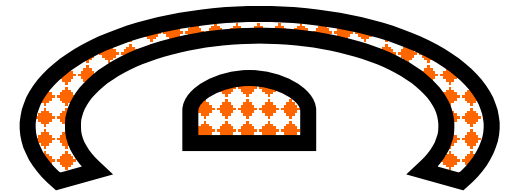
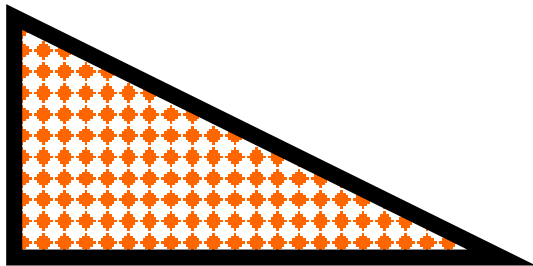
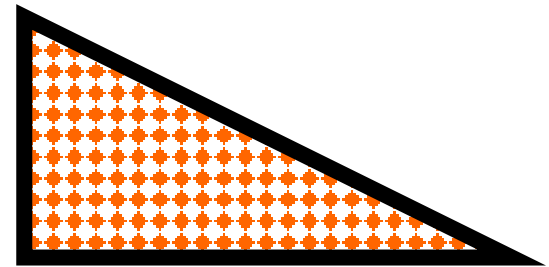
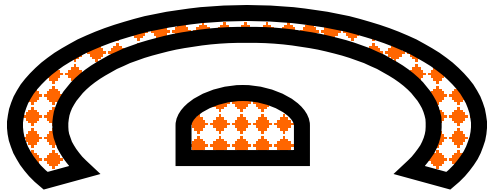

ASSOCIAZIONI DI IMMAGINI UGUALI O SIMILI
Associare le immagini uguali o simili.

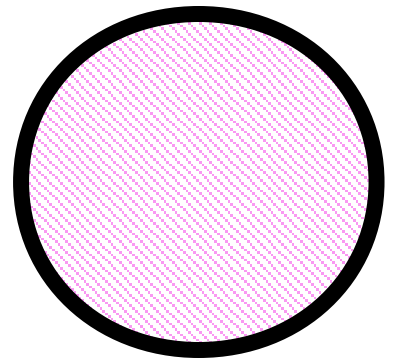
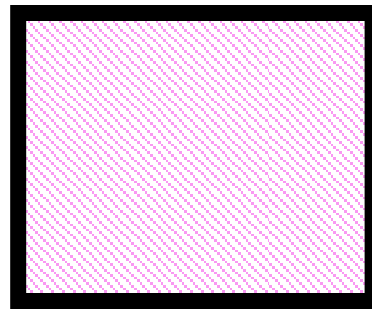
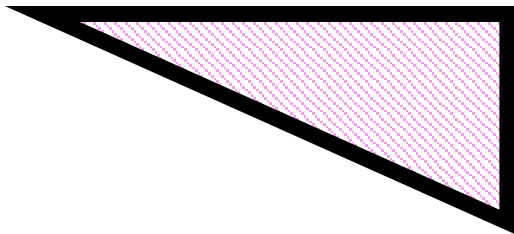
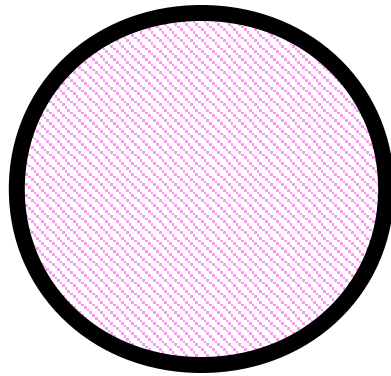

ASSOCIAZIONI DI IMMAGINI UGUALI O SIMILI
Associare le immagini uguali o simili.

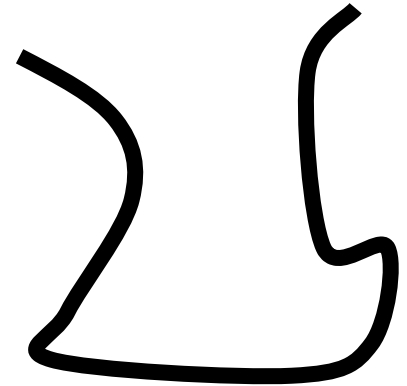
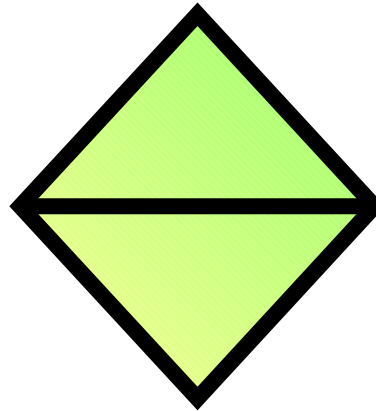
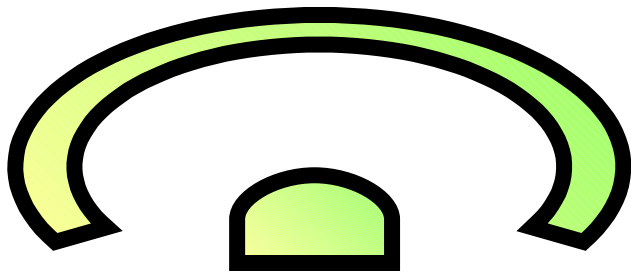
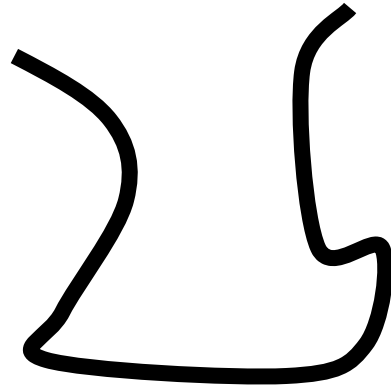

ASSOCIAZIONI DI IMMAGINI UGUALI O SIMILI
Associare le immagini uguali o simili.

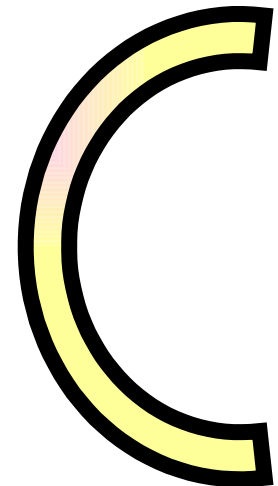
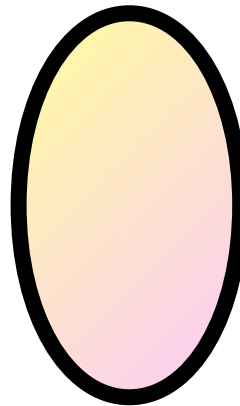
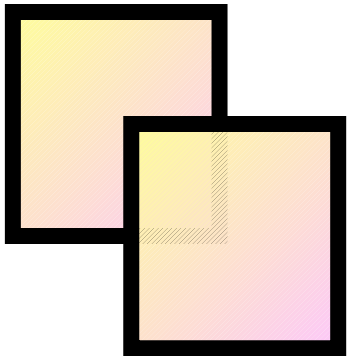
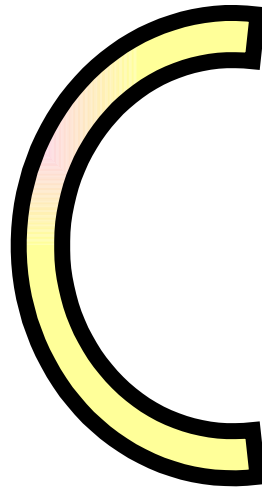

ASSOCIAZIONI DI IMMAGINI UGUALI O SIMILI
Associare le immagini uguali o simili.

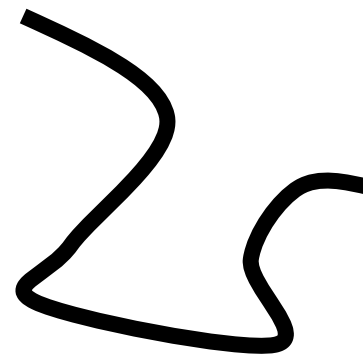
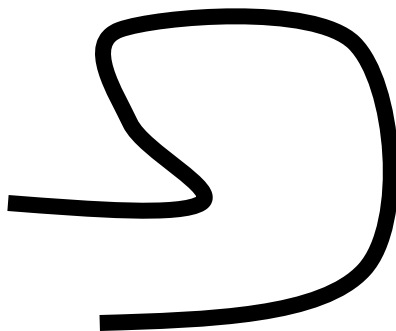

ASSOCIAZIONI DI IMMAGINI UGUALI O SIMILI
Associare le immagini uguali o simili.

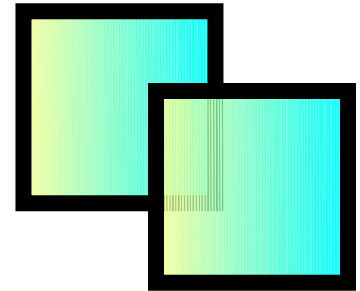
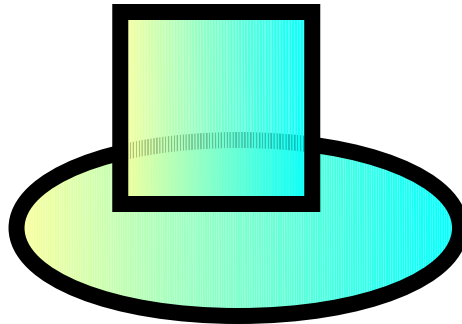
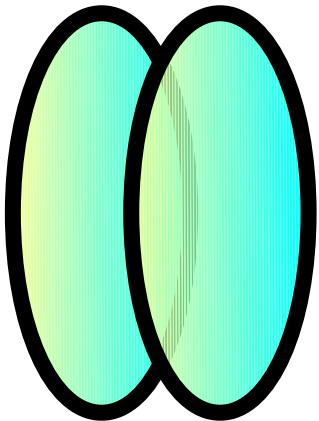
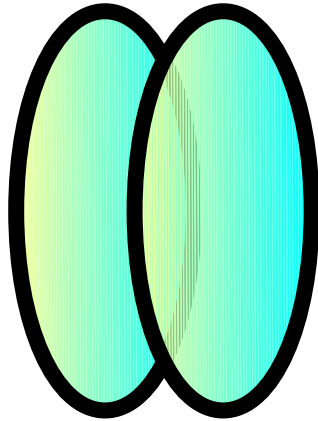

ASSOCIAZIONI DI IMMAGINI UGUALI O SIMILI
Associare le immagini uguali o simili.

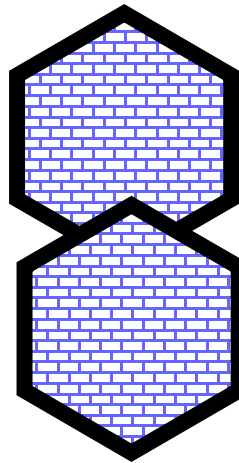
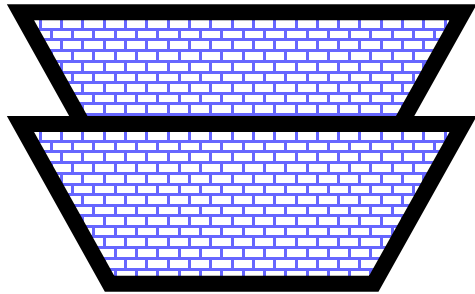
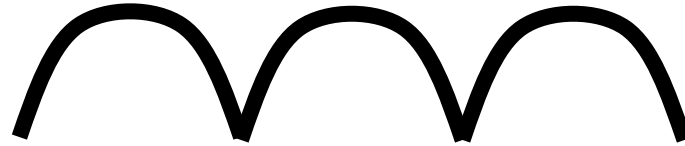

ASSOCIAZIONI DI IMMAGINI UGUALI O SIMILI
Associare le immagini uguali o simili.

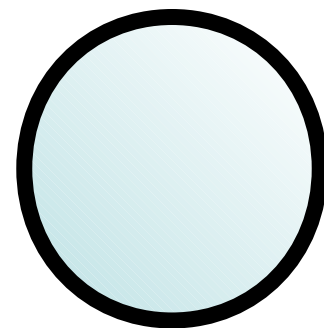
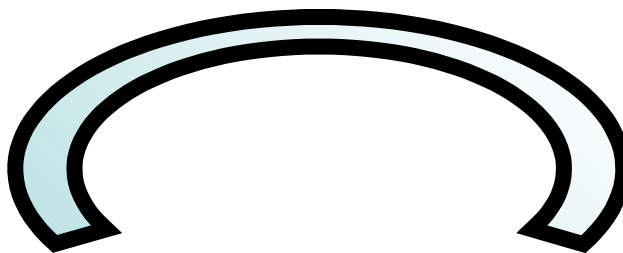
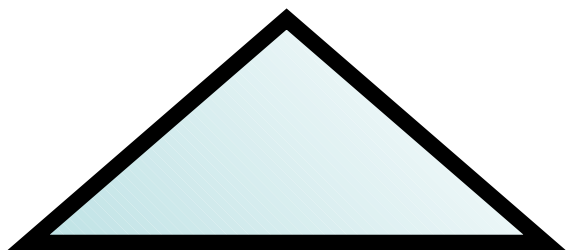
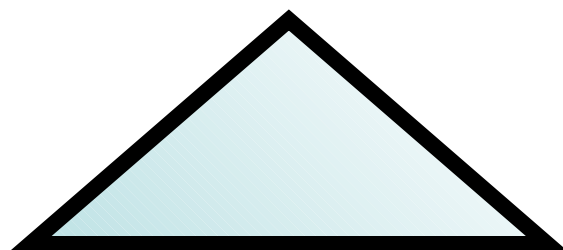

ASSOCIAZIONI DI IMMAGINI UGUALI O SIMILI
Associare le immagini uguali o simili.

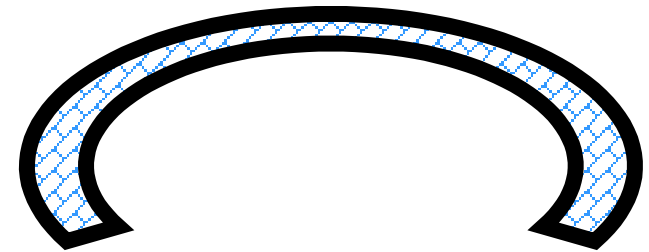
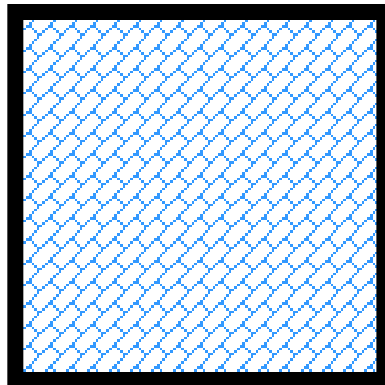
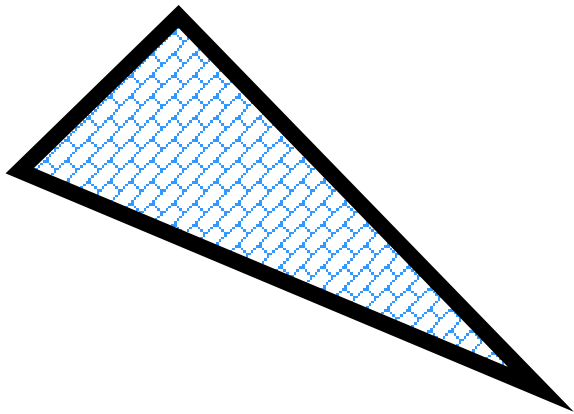
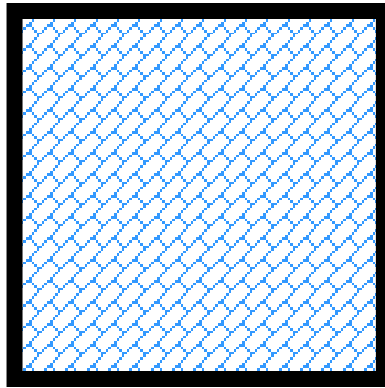

ASSOCIAZIONI DI IMMAGINI UGUALI O SIMILI
Associare le immagini uguali o simili.

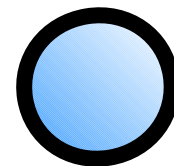
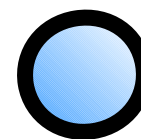
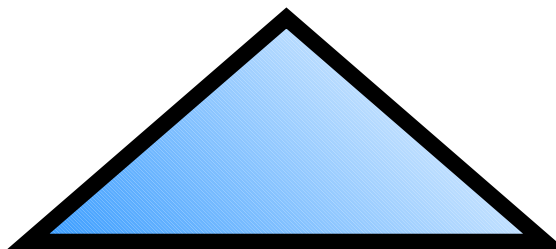
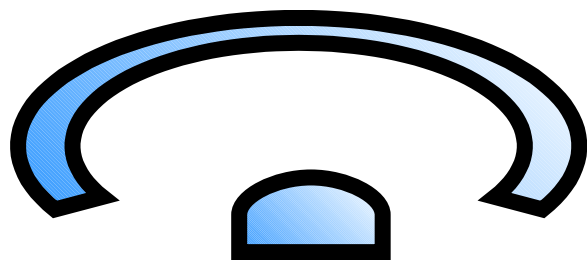
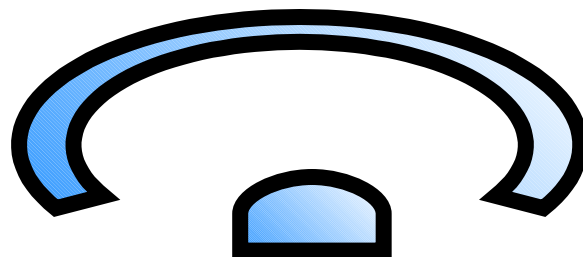

ASSOCIAZIONI DI IMMAGINI UGUALI O SIMILI
Associare le immagini uguali o simili.

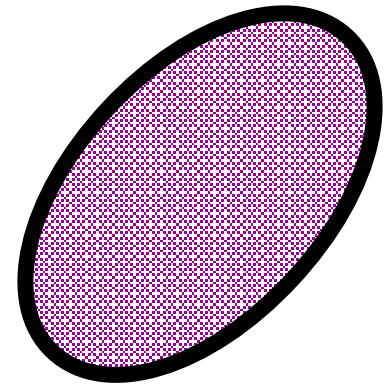
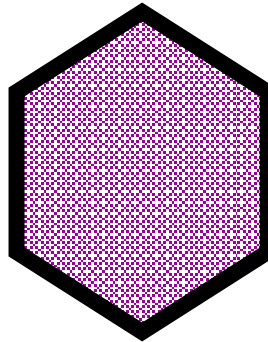
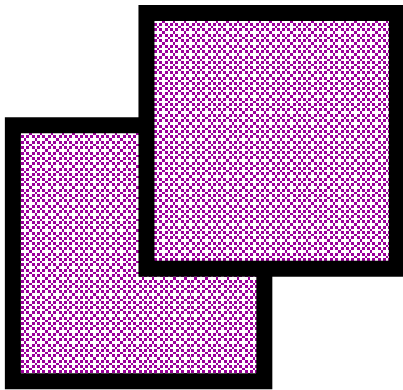
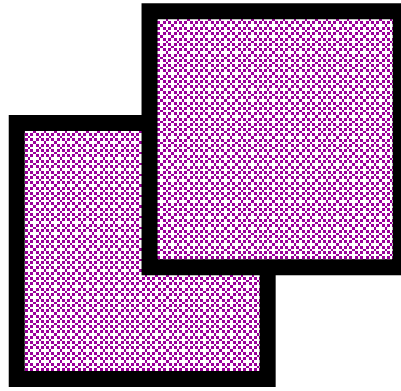

ASSOCIAZIONI DI IMMAGINI UGUALI O SIMILI
Associare le immagini uguali o simili.

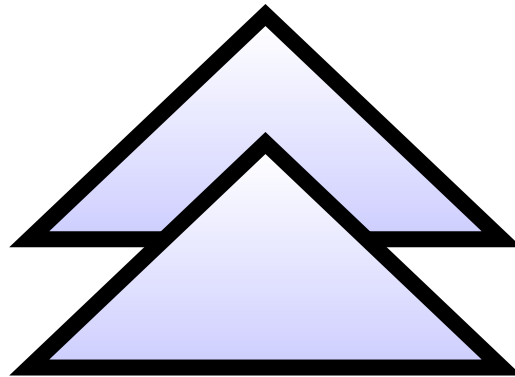
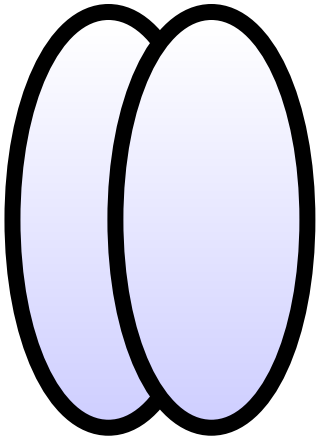
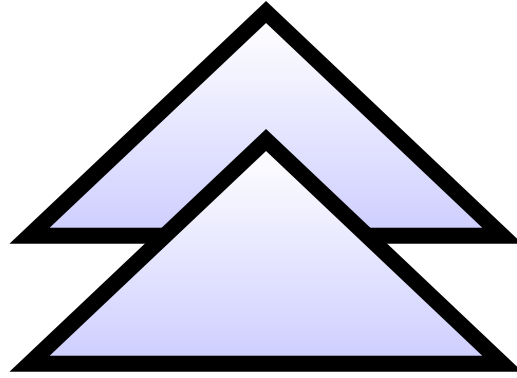

ASSOCIAZIONI DI IMMAGINI UGUALI O SIMILI
Associare le immagini uguali o simili.

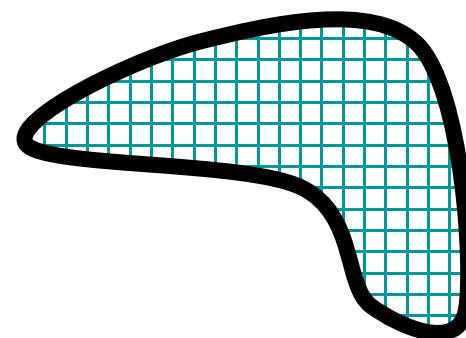
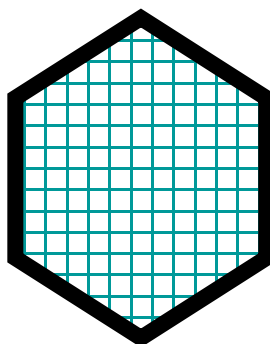
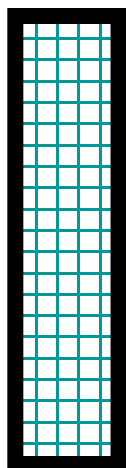
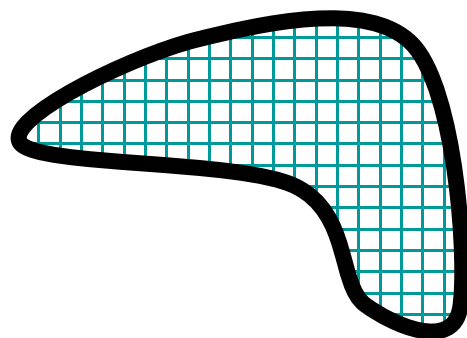

ASSOCIAZIONI DI IMMAGINI UGUALI O SIMILI
Associare le immagini uguali o simili.

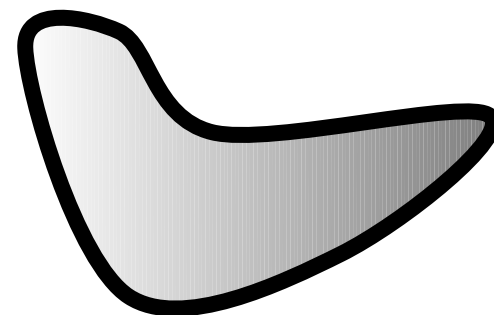
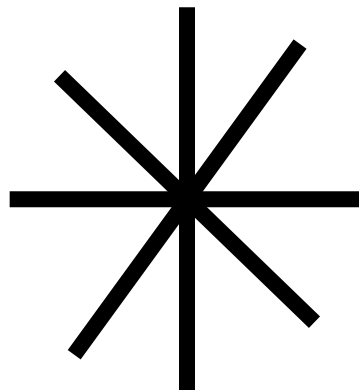
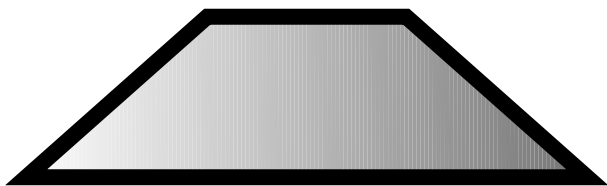
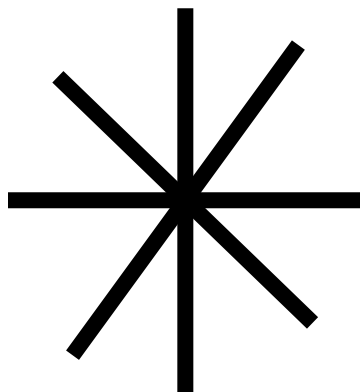

ASSOCIAZIONI DI IMMAGINI UGUALI O SIMILI
Associare le immagini uguali o simili.

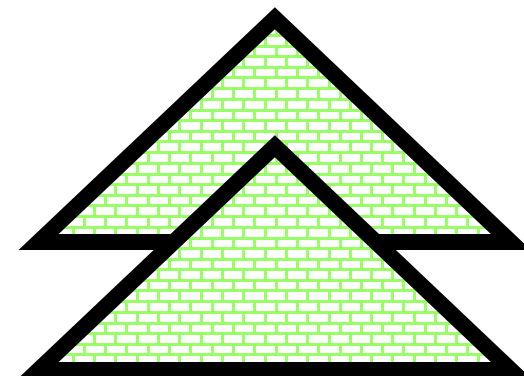
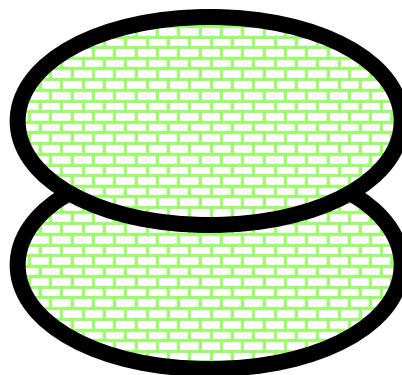
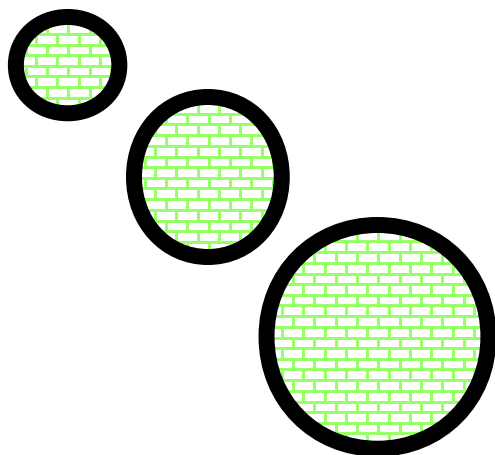
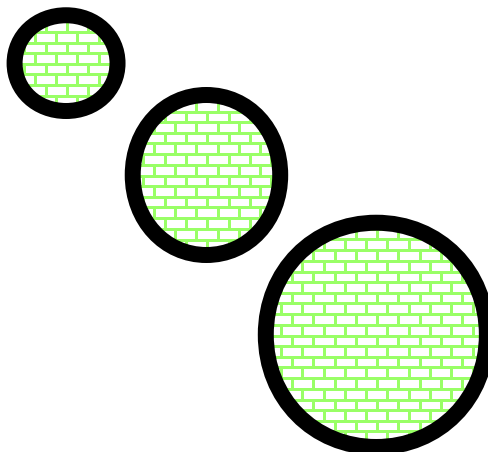

ASSOCIAZIONI DI IMMAGINI UGUALI O SIMILI
Associare le immagini uguali o simili.

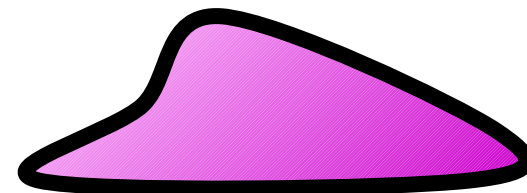
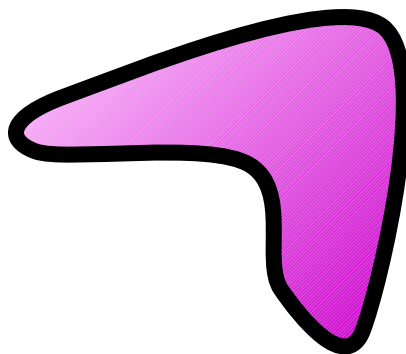
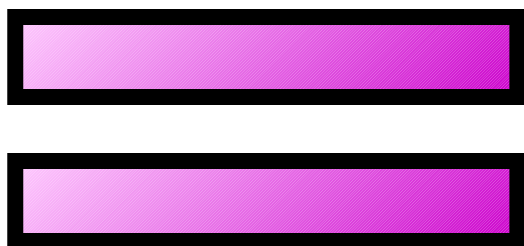

ASSOCIAZIONI DI IMMAGINI UGUALI O SIMILI
Associare le immagini uguali o simili.

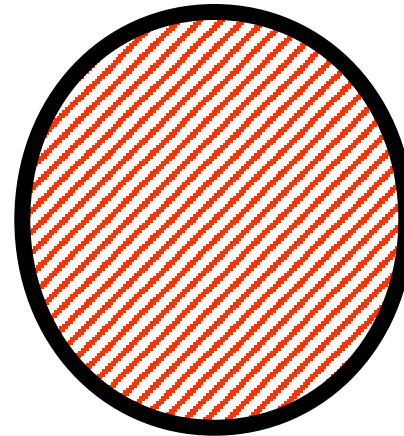
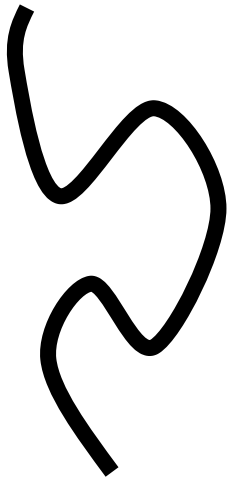
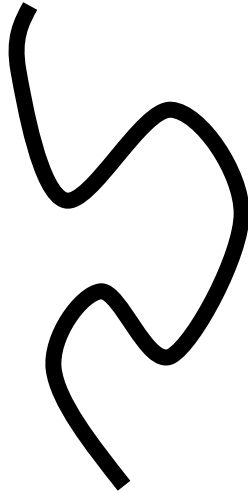

ASSOCIAZIONI DI IMMAGINI UGUALI O SIMILI
Associare le immagini uguali o simili.

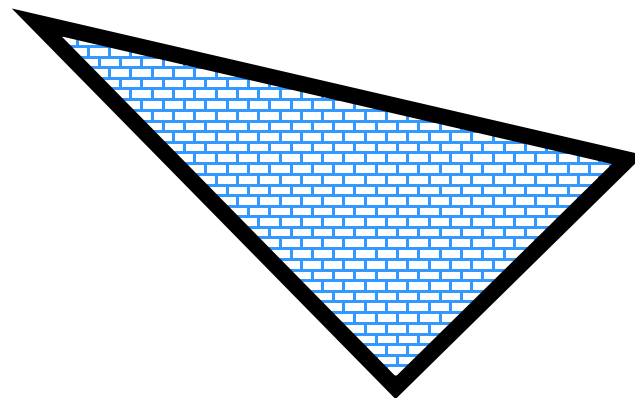
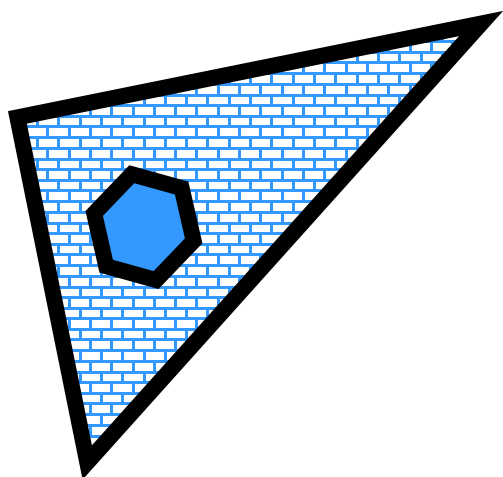
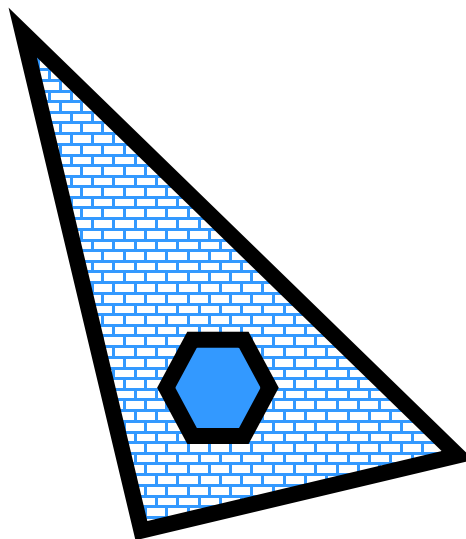

ASSOCIAZIONI DI IMMAGINI UGUALI O SIMILI
Associare le immagini uguali o simili.

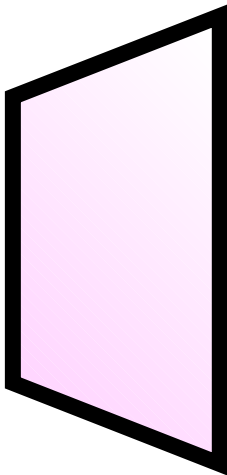
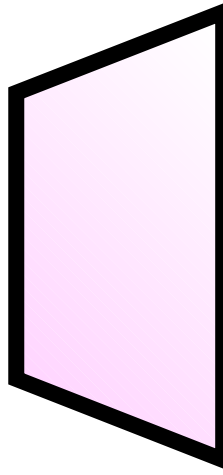

ASSOCIAZIONI DI IMMAGINI UGUALI O SIMILI
Associare le immagini uguali o simili.

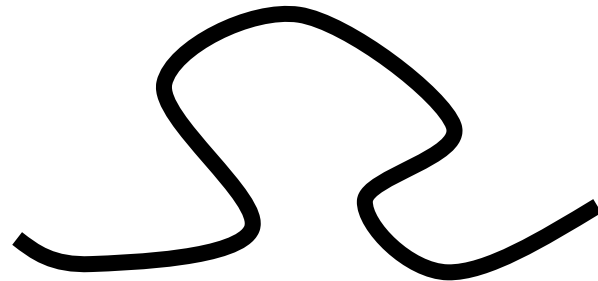
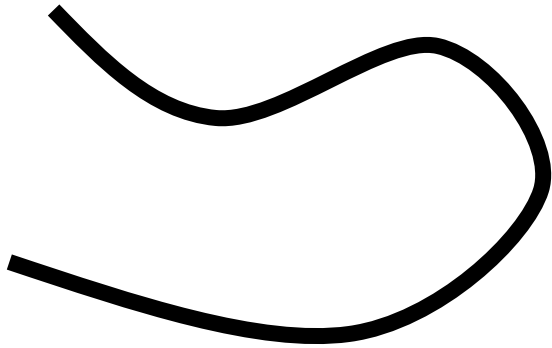
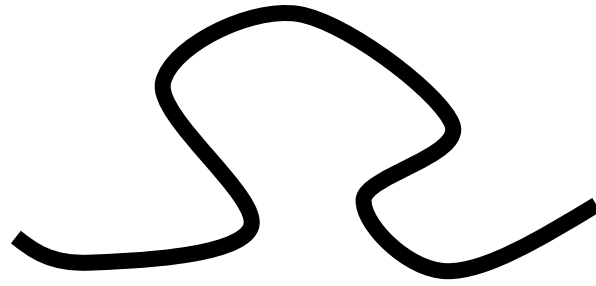

ASSOCIAZIONI DI IMMAGINI UGUALI O SIMILI
Associare le immagini uguali o simili.

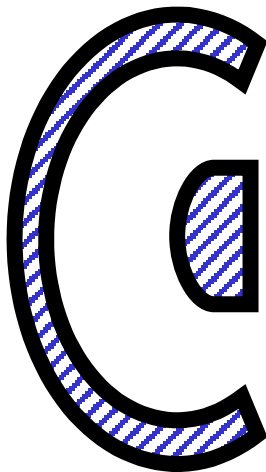
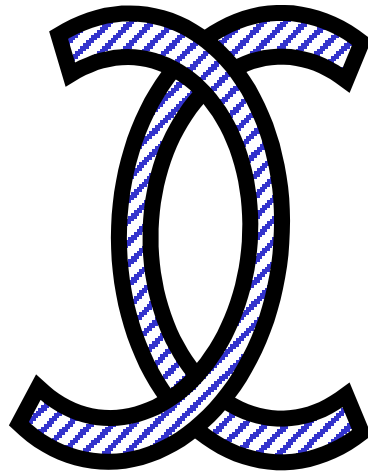

ASSOCIAZIONI DI IMMAGINI UGUALI O SIMILI
Associare le immagini uguali o simili.

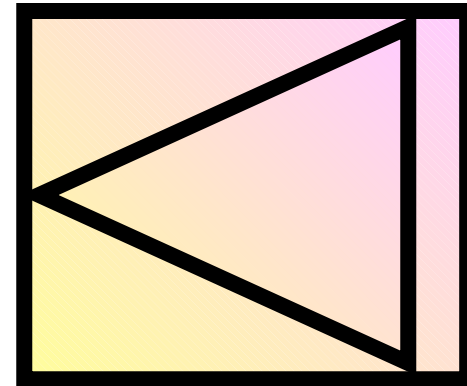
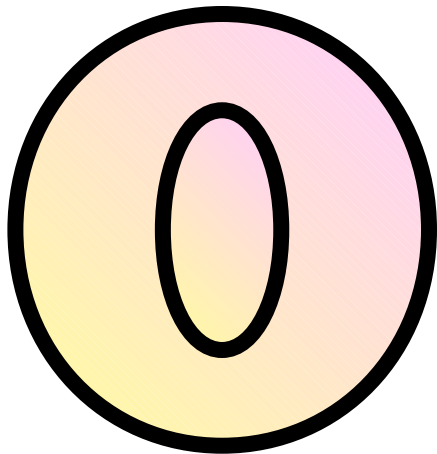
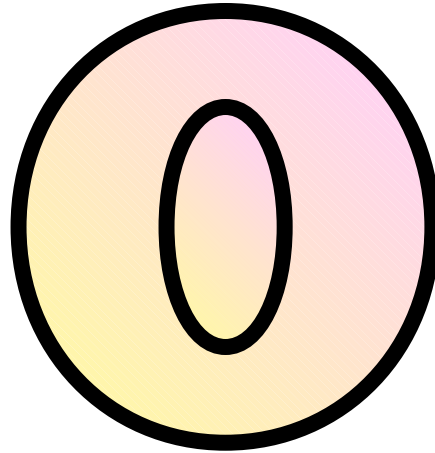

ASSOCIAZIONI DI IMMAGINI UGUALI O SIMILI
Associare le immagini uguali o simili.

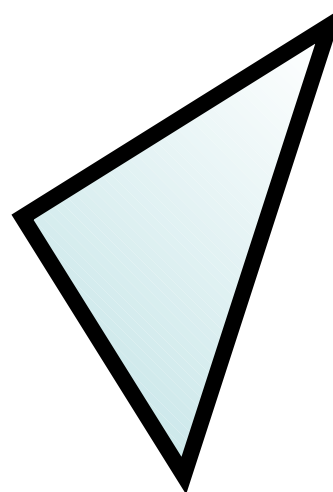
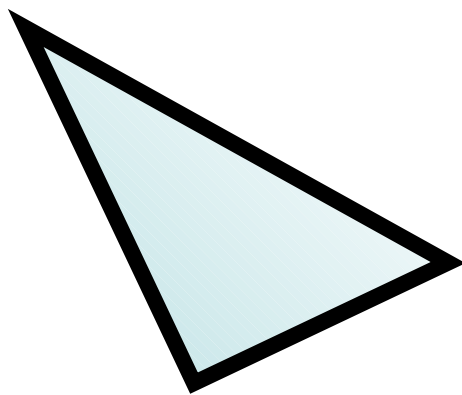
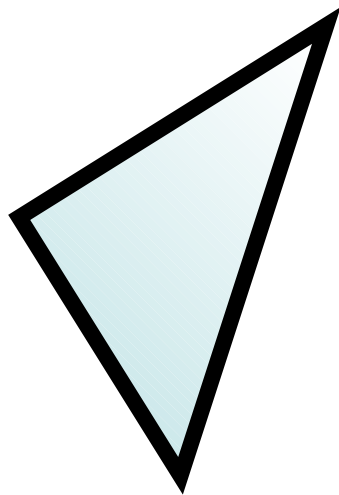

ASSOCIAZIONI DI IMMAGINI UGUALI O SIMILI
Associare le immagini uguali o simili.

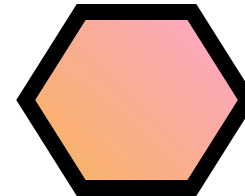
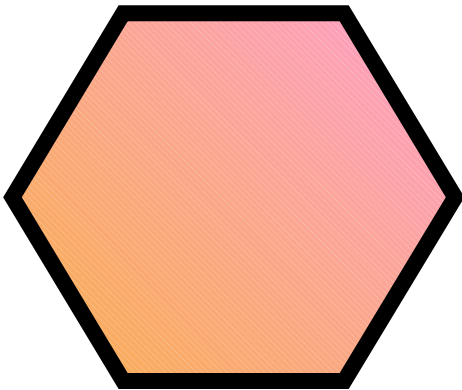
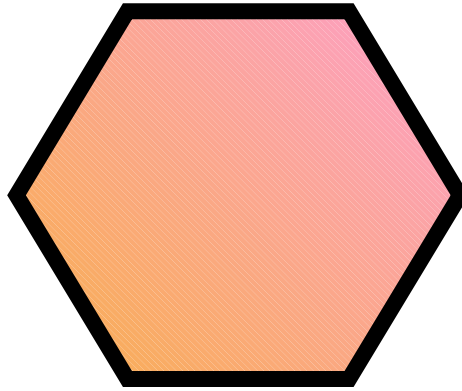

ASSOCIAZIONI DI IMMAGINI UGUALI O SIMILI
Associare le immagini uguali o simili.

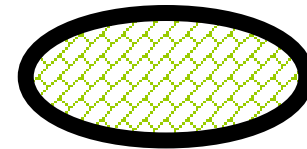
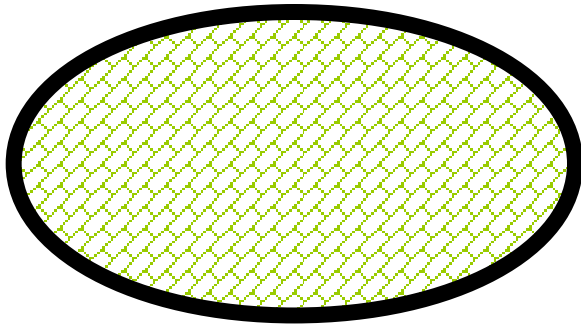
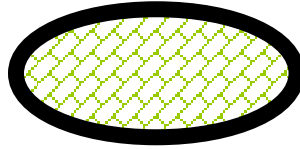

ASSOCIAZIONI DI IMMAGINI UGUALI O SIMILI
Associare le immagini uguali o simili.

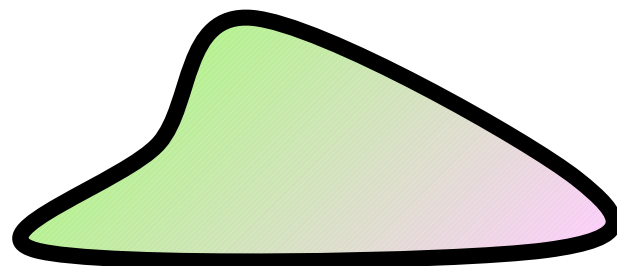

ASSOCIAZIONI DI IMMAGINI UGUALI O SIMILI
Associare le immagini uguali o simili.

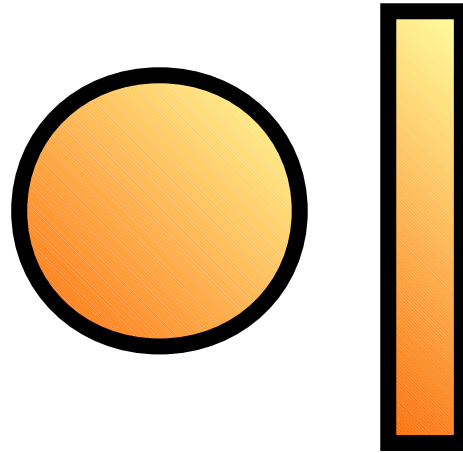

ASSOCIAZIONI DI IMMAGINI UGUALI O SIMILI
Associare le immagini uguali o simili.

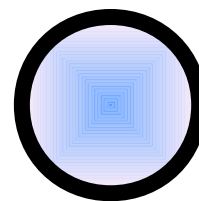
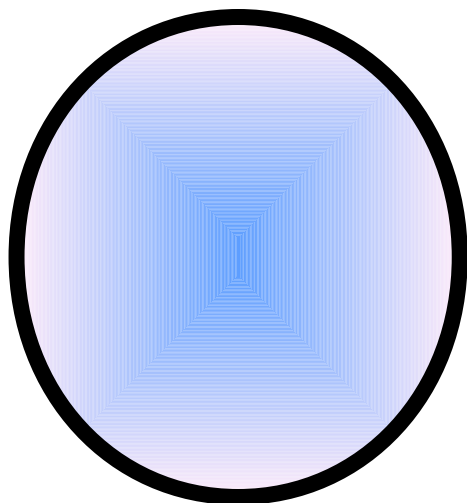
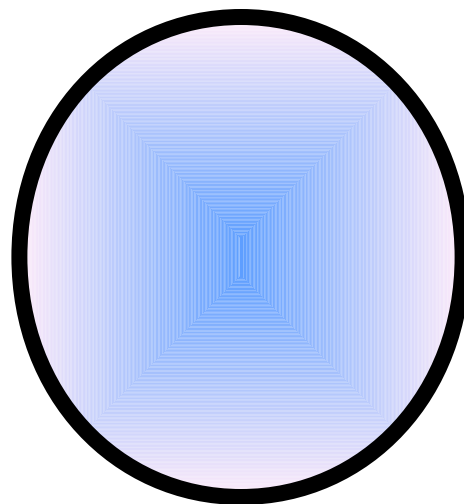

ASSOCIAZIONI DI IMMAGINI UGUALI O SIMILI
Associare le immagini uguali o simili.

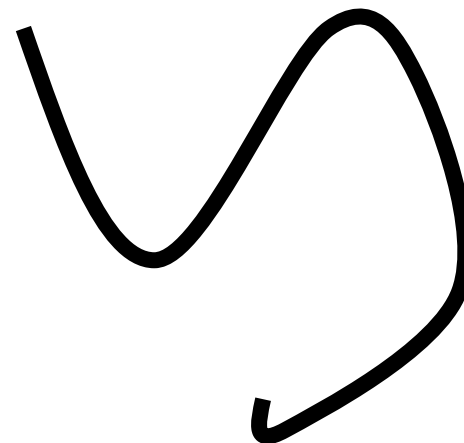
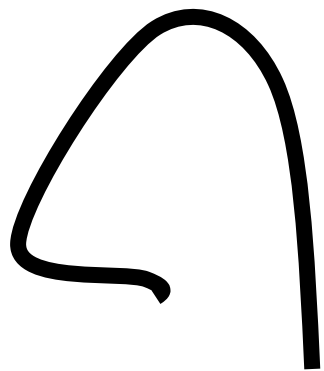
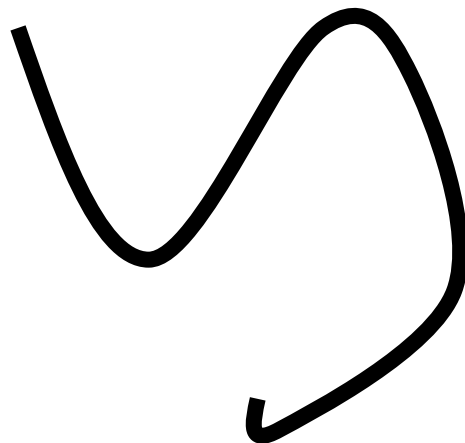

ASSOCIAZIONI DI IMMAGINI UGUALI O SIMILI
Associare le immagini uguali o simili.

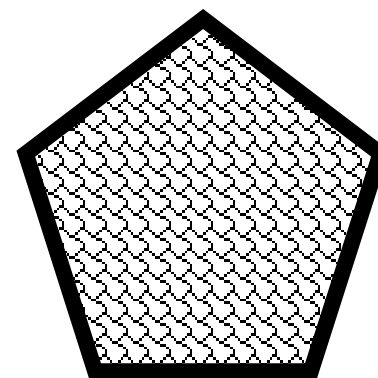
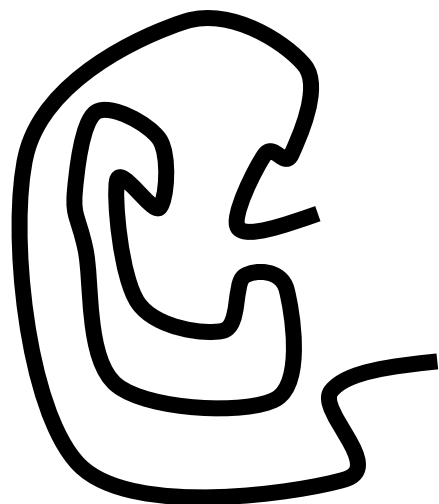
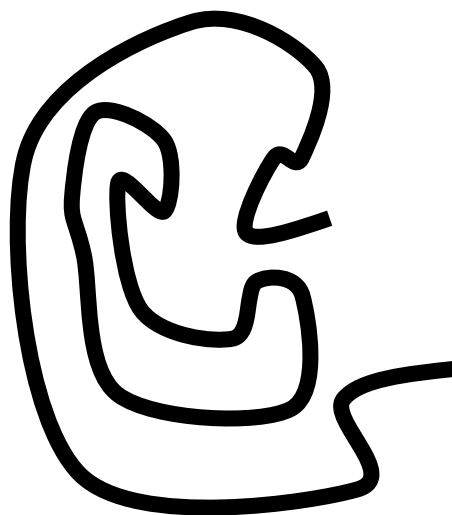

ASSOCIAZIONI DI IMMAGINI UGUALI O SIMILI
Associare le immagini uguali o simili.

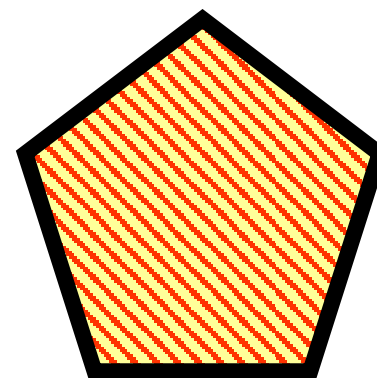
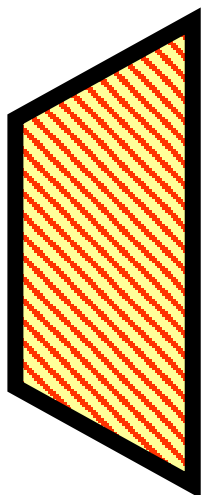
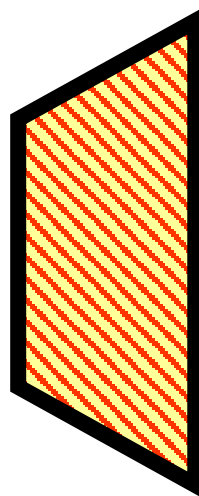

ASSOCIAZIONI DI IMMAGINI UGUALI O SIMILI
Associare le immagini uguali o simili.

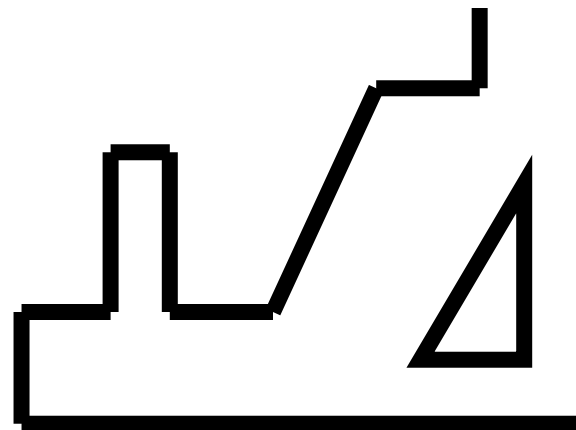

ASSOCIAZIONI DI IMMAGINI UGUALI O SIMILI
Associare le immagini uguali o simili.

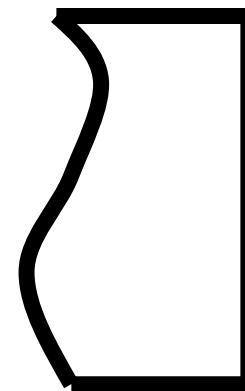
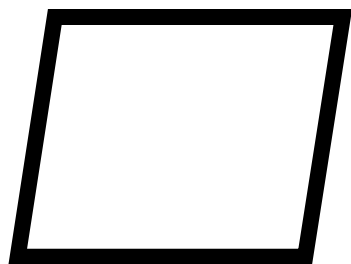
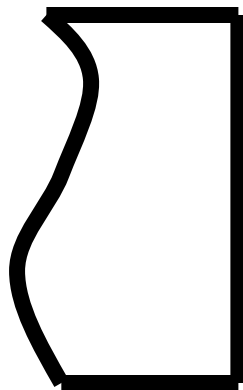

ASSOCIAZIONI DI IMMAGINI UGUALI O SIMILI
Associare le immagini uguali o simili.

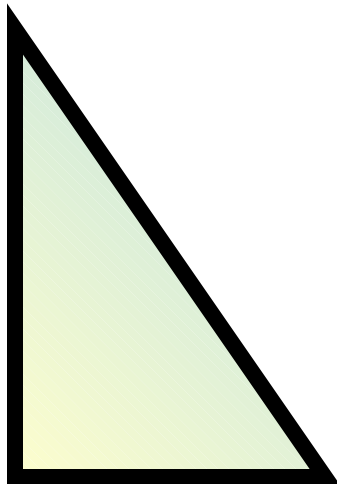
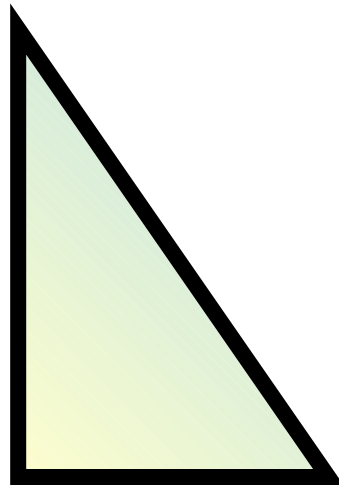

ASSOCIAZIONI DI IMMAGINI UGUALI O SIMILI
Associare le immagini uguali o simili.

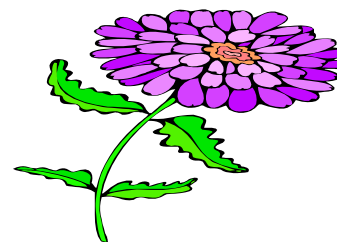
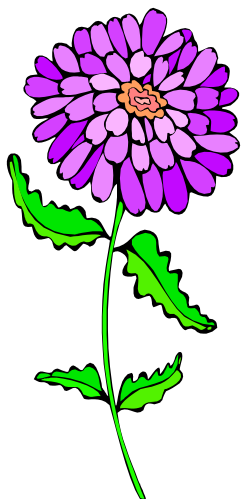

ASSOCIAZIONI DI IMMAGINI UGUALI O SIMILI
Associare le immagini uguali o simili.

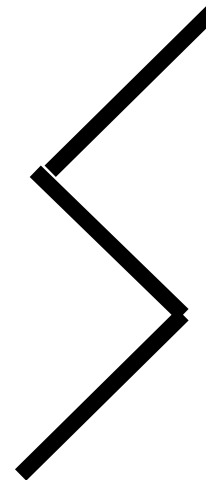
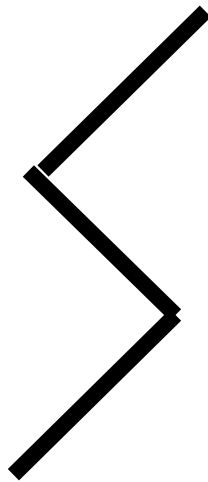

ASSOCIAZIONI DI IMMAGINI UGUALI O SIMILI
Associare le immagini uguali o simili.

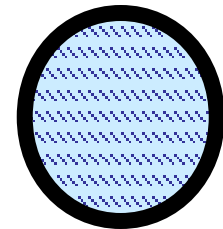
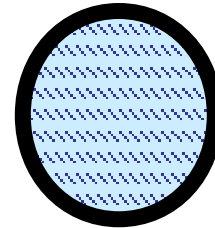
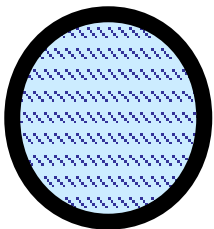
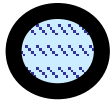
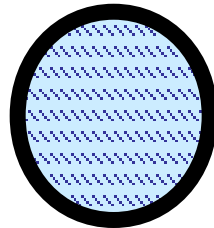
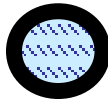

ASSOCIAZIONI DI IMMAGINI UGUALI O SIMILI
Associare le immagini uguali o simili.

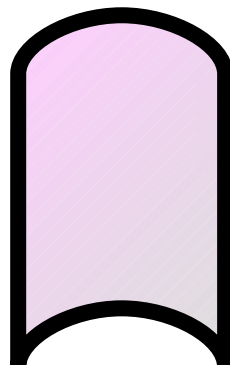

ASSOCIAZIONI DI IMMAGINI UGUALI O SIMILI
Associare le immagini uguali o simili.

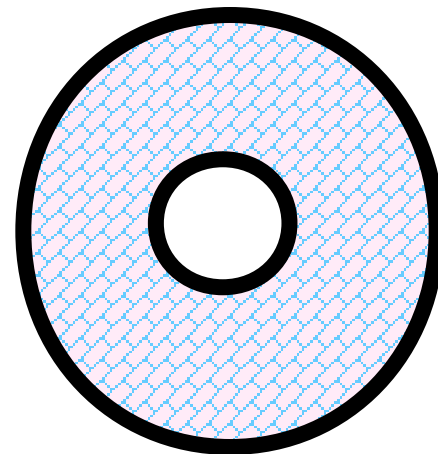
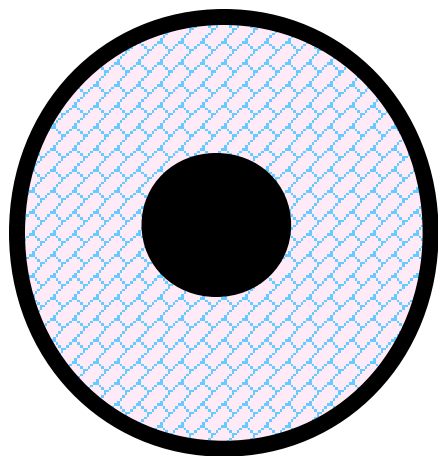
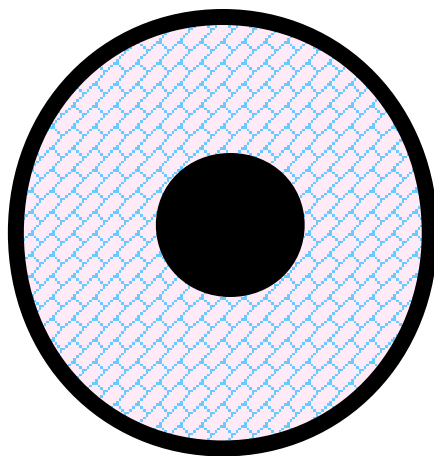

ASSOCIAZIONI DI IMMAGINI UGUALI O SIMILI
Associare le immagini uguali o simili.

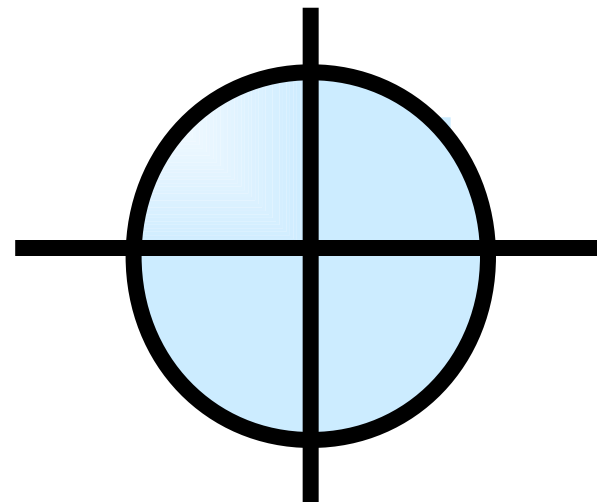
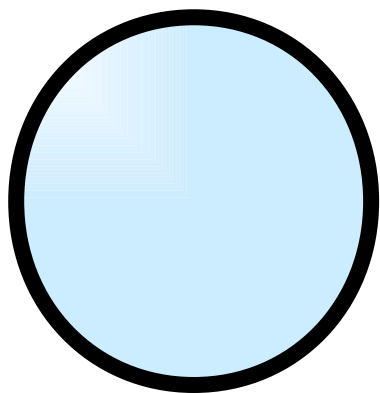
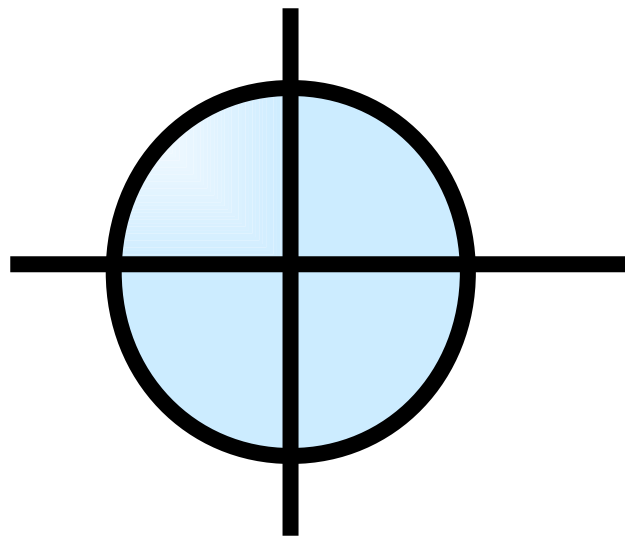

ASSOCIAZIONI DI IMMAGINI UGUALI O SIMILI
Associare le immagini uguali o simili.

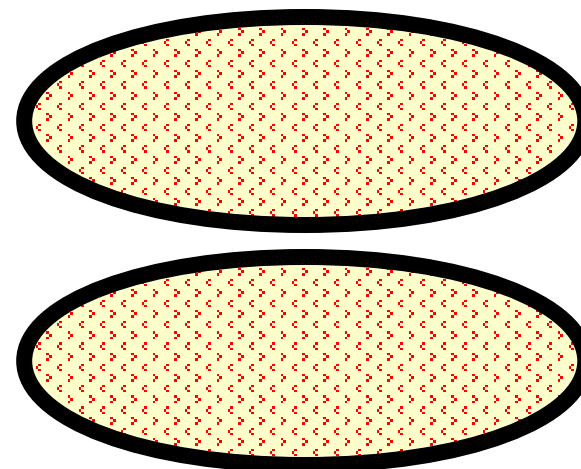
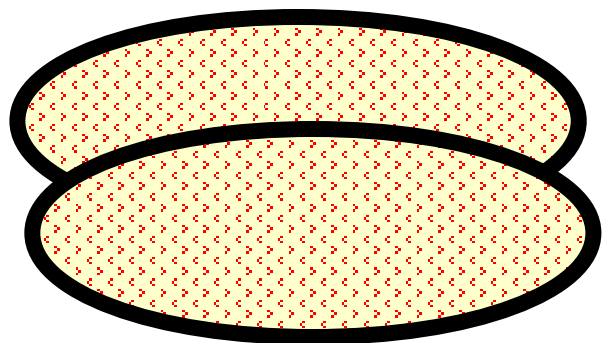
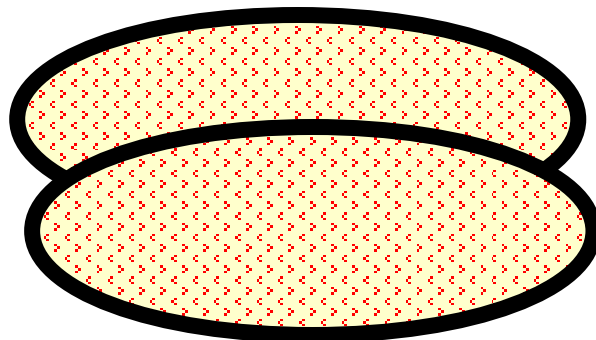

ASSOCIAZIONI DI IMMAGINI UGUALI O SIMILI
Associare le immagini uguali o simili.

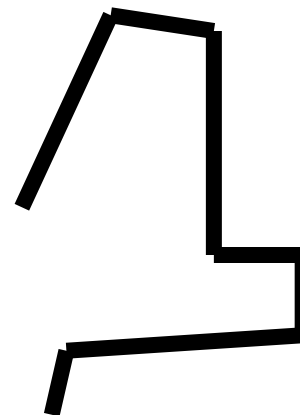
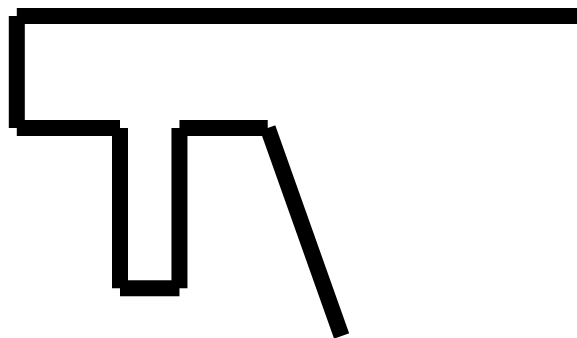
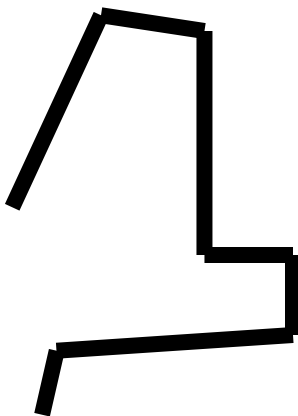

ASSOCIAZIONI DI IMMAGINI UGUALI O SIMILI
Associare le immagini uguali o simili.

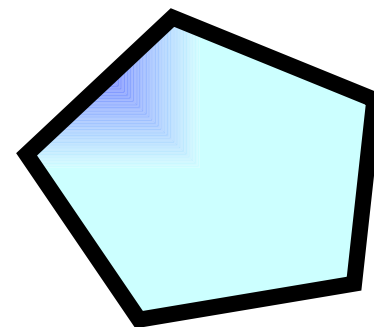
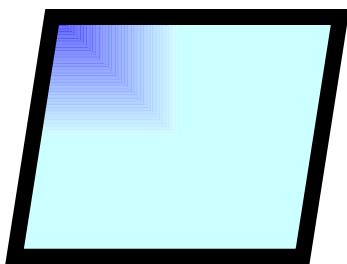
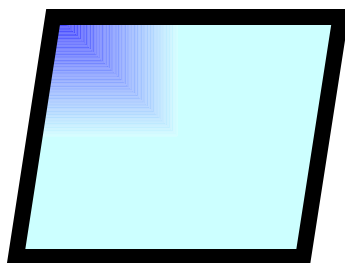

ASSOCIAZIONI DI IMMAGINI UGUALI O SIMILI
Associare le immagini uguali o simili.

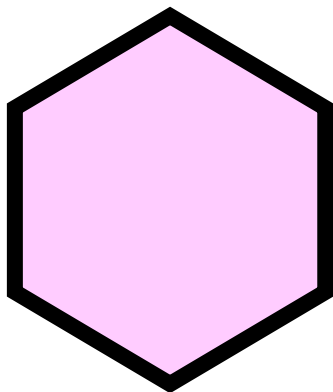
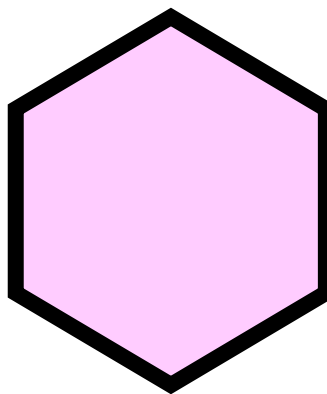

ASSOCIAZIONI DI IMMAGINI UGUALI O SIMILI
Associare le immagini uguali o simili.

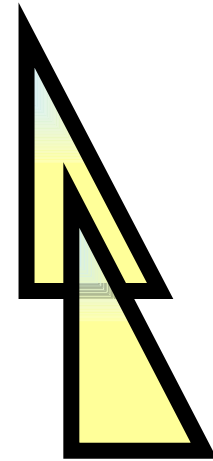
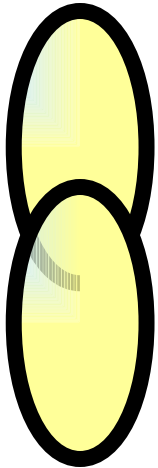
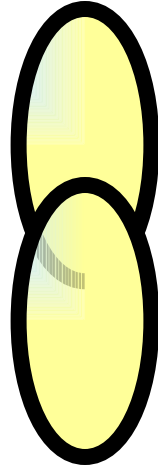

ASSOCIAZIONI DI IMMAGINI UGUALI O SIMILI
Associare le immagini uguali o simili.

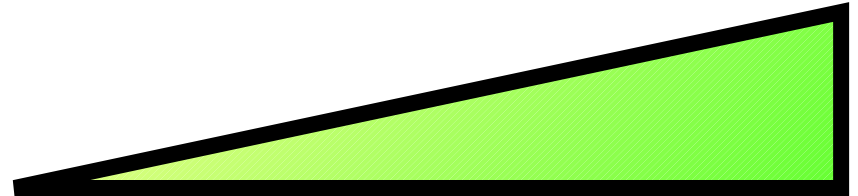
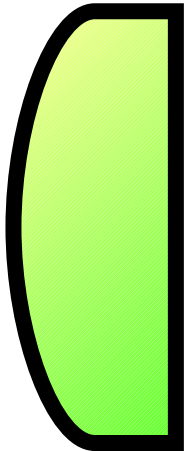
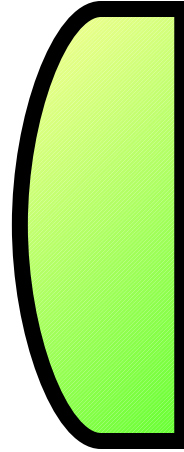

ASSOCIAZIONI DI IMMAGINI UGUALI O SIMILI
Associare le immagini uguali o simili.

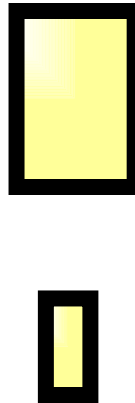
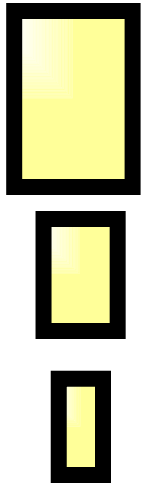
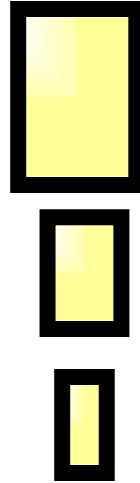

ASSOCIAZIONI DI IMMAGINI UGUALI O SIMILI
Associare le immagini uguali o simili.

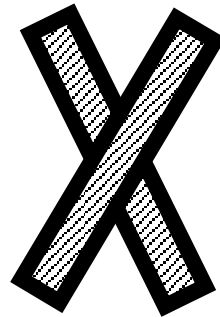
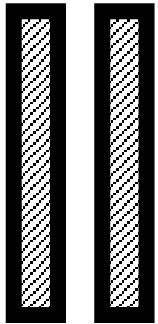

ASSOCIAZIONI DI IMMAGINI UGUALI O SIMILI
Associare le immagini uguali o simili.

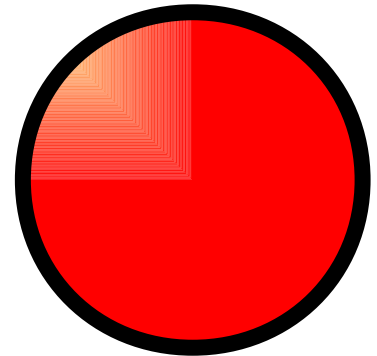
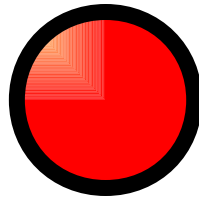
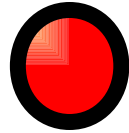

ASSOCIAZIONI DI IMMAGINI UGUALI O SIMILI
Associare le immagini uguali o simili.

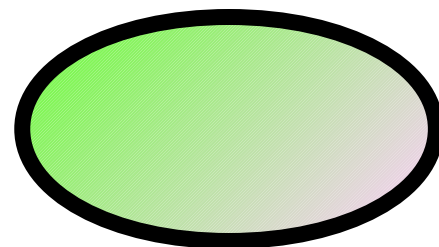
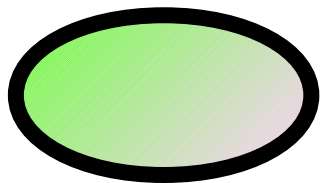
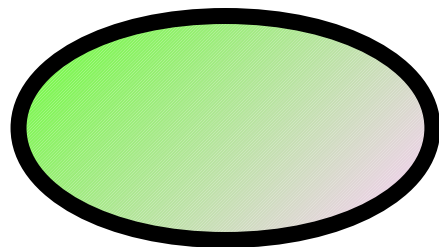

ASSOCIAZIONI DI IMMAGINI UGUALI O SIMILI
Associare le immagini uguali o simili.

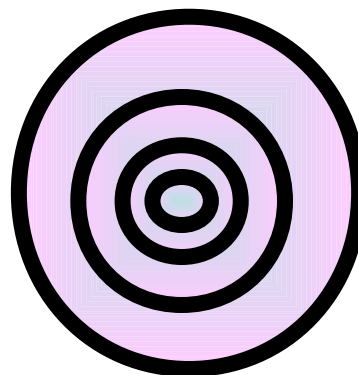
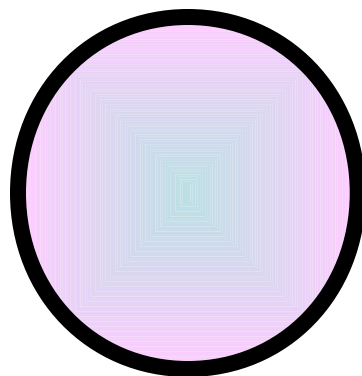
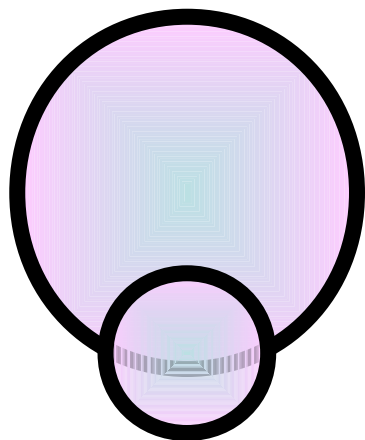
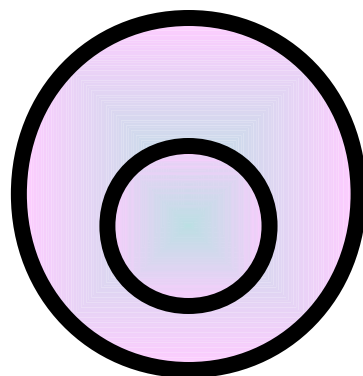

ASSOCIAZIONI DI IMMAGINI UGUALI O SIMILI
Associare le immagini uguali o simili.

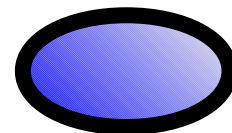
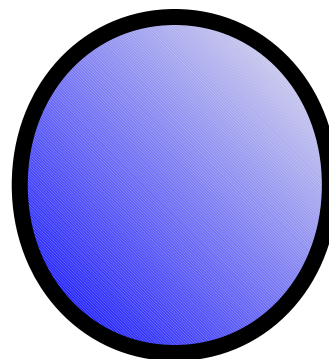
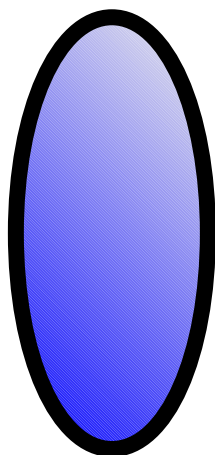
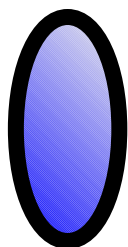
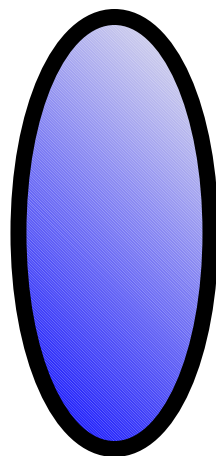

ASSOCIAZIONI DI IMMAGINI UGUALI O SIMILI
Associare le immagini uguali o simili.

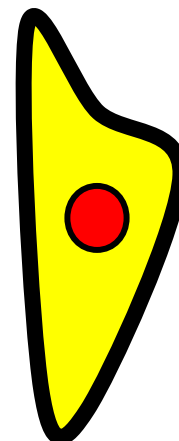
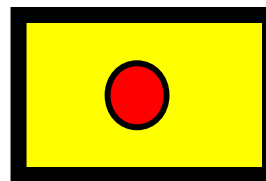
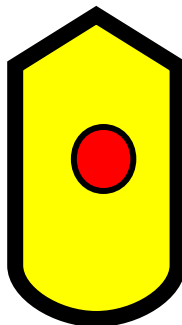
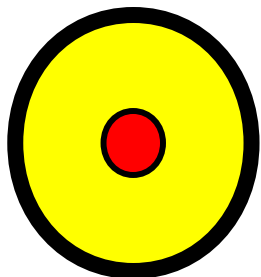
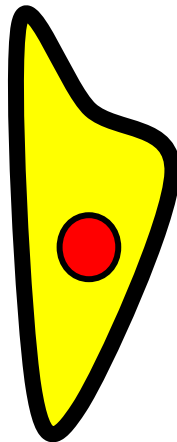

ASSOCIAZIONI DI IMMAGINI UGUALI O SIMILI
Associare le immagini uguali o simili.

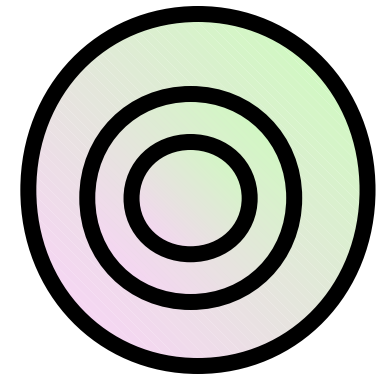
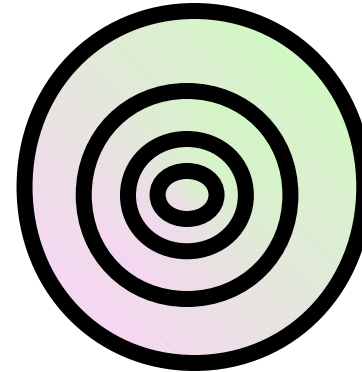
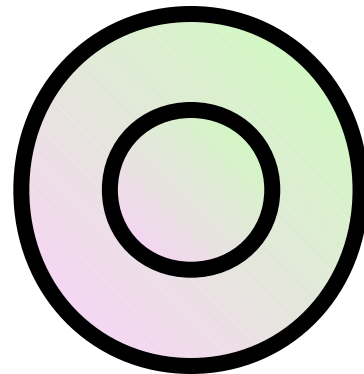
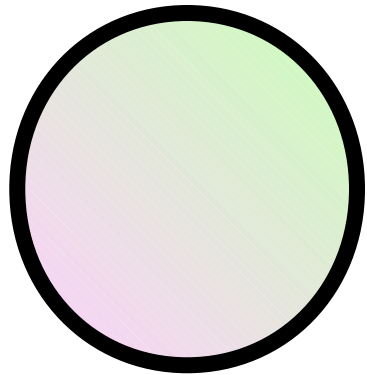
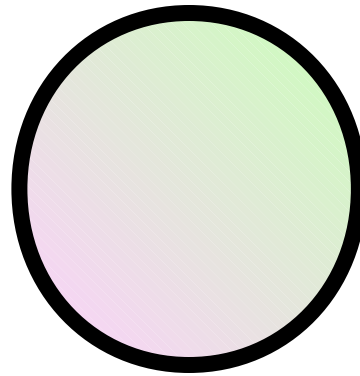

ASSOCIAZIONI DI IMMAGINI UGUALI O SIMILI
Associare le immagini uguali o simili.

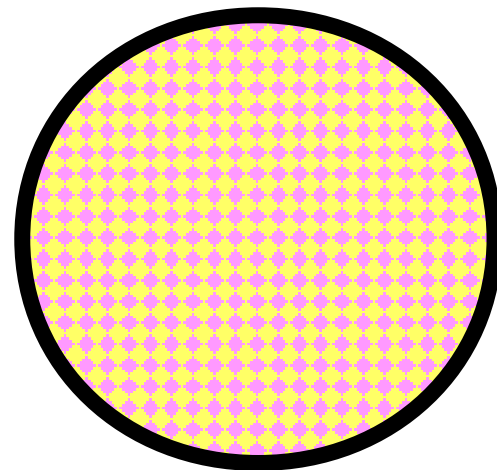
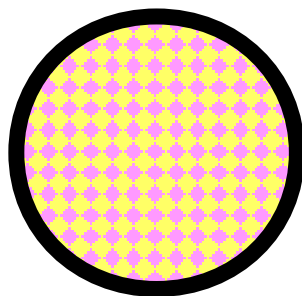
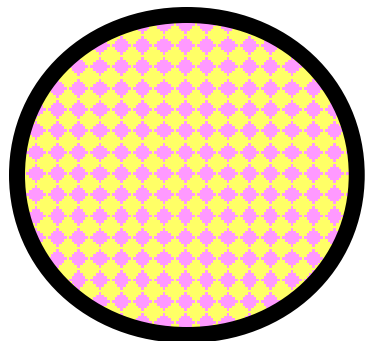
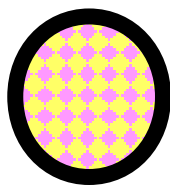
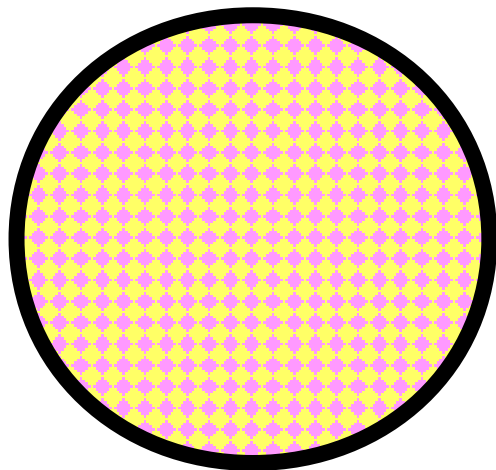

ASSOCIAZIONI DI IMMAGINI UGUALI O SIMILI
Associare le immagini uguali o simili.

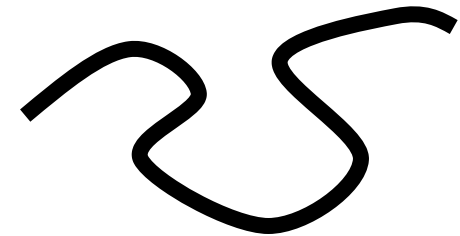
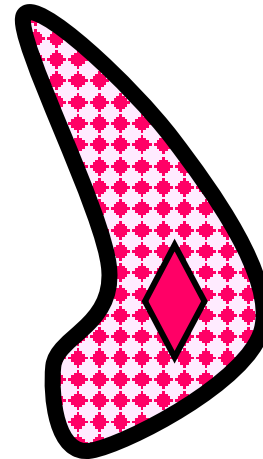
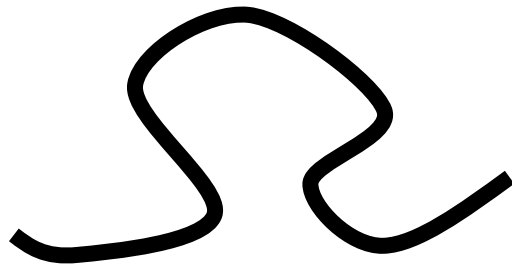
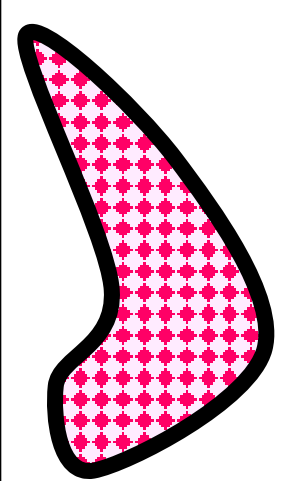
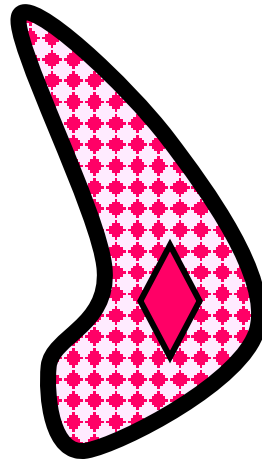

ASSOCIAZIONI DI IMMAGINI UGUALI O SIMILI
Associare le immagini uguali o simili.

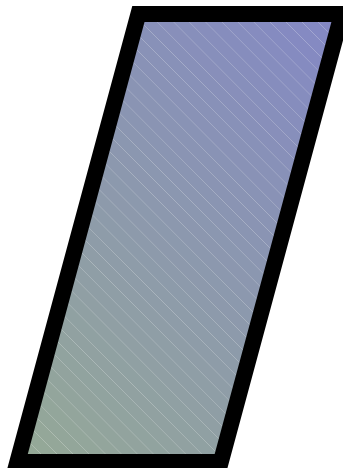
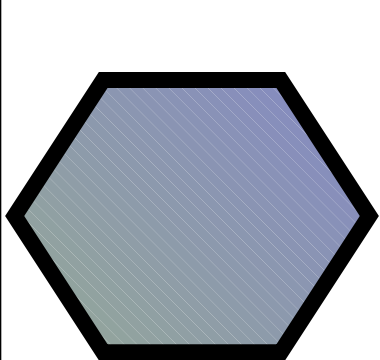
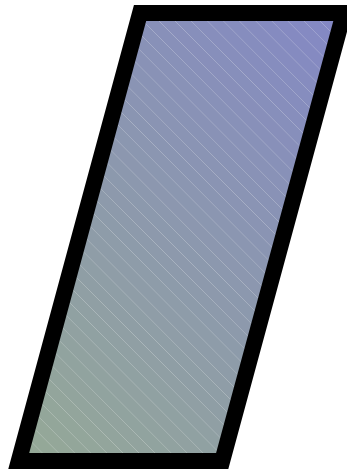

ASSOCIAZIONI DI IMMAGINI UGUALI O SIMILI
Associare le immagini uguali o simili.

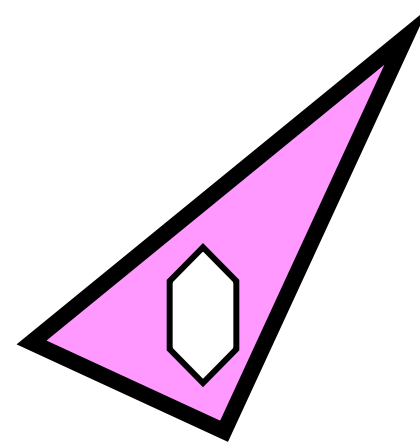
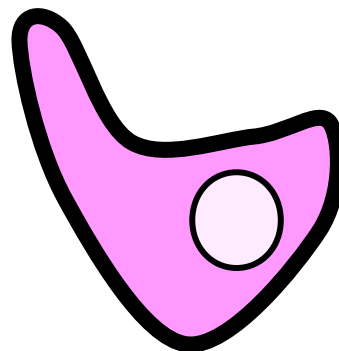
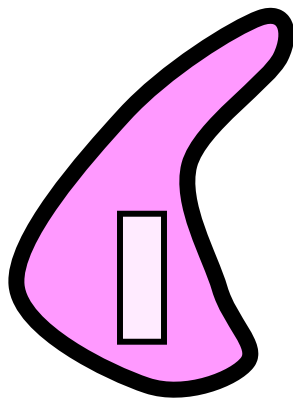
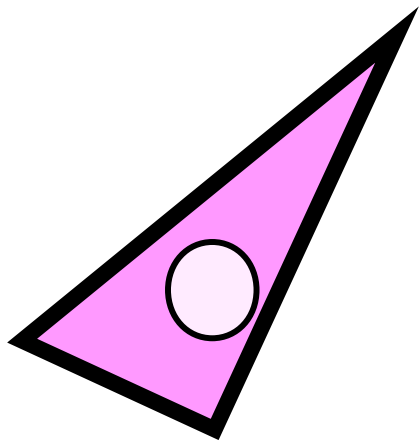
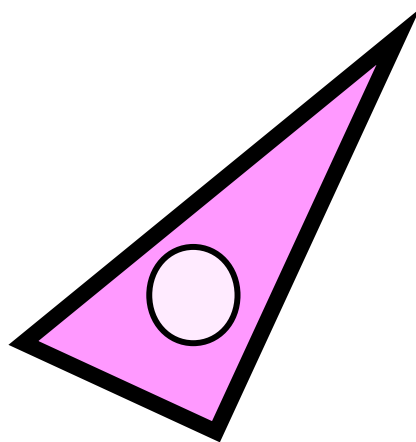

ASSOCIAZIONI DI IMMAGINI UGUALI O SIMILI
Associare le immagini uguali o simili.

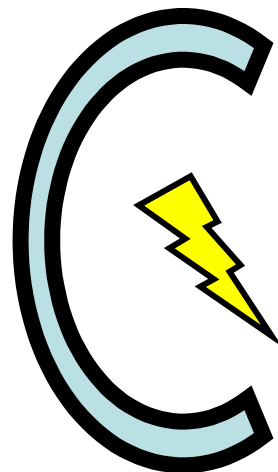
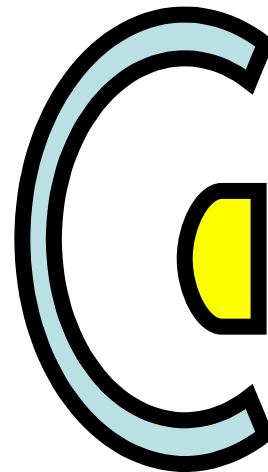
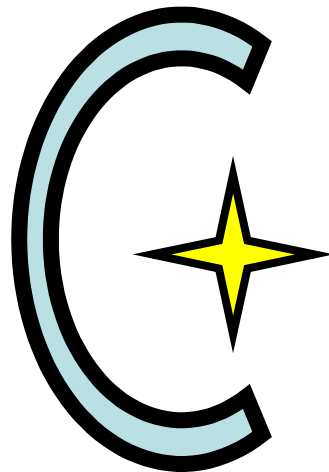
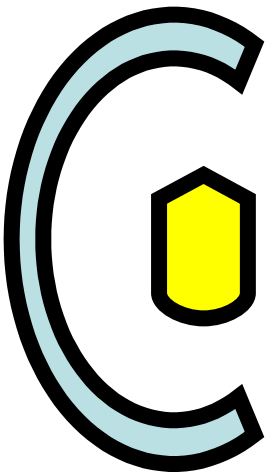
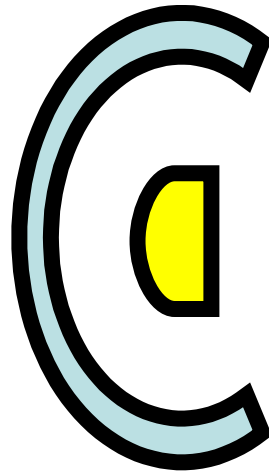

ASSOCIAZIONI DI IMMAGINI UGUALI O SIMILI
Associare le immagini uguali o simili.

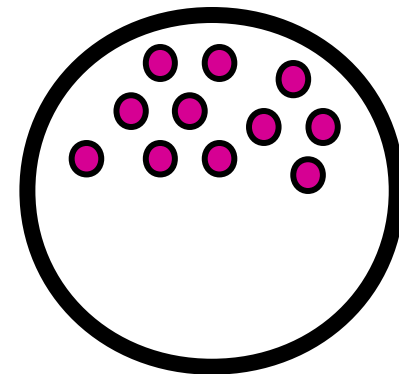
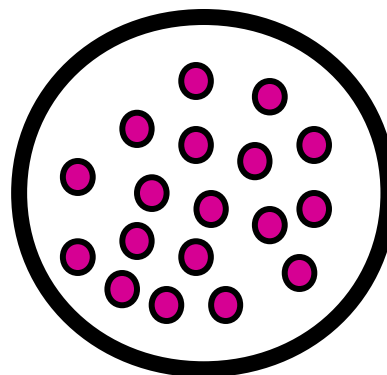
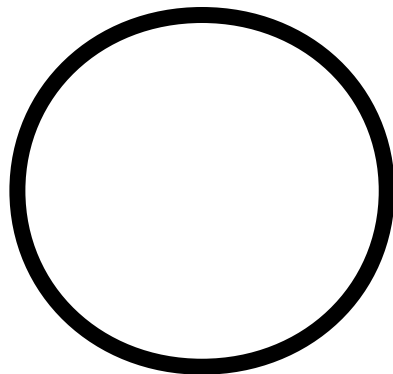
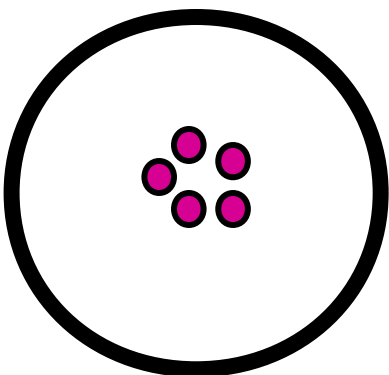
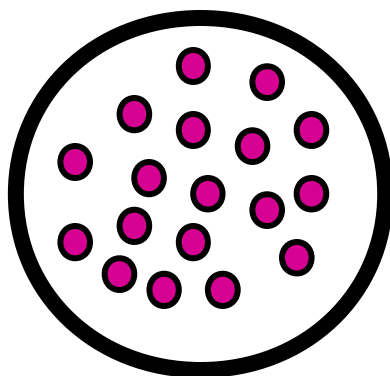

ASSOCIAZIONI DI IMMAGINI UGUALI O SIMILI
Associare le immagini uguali o simili.

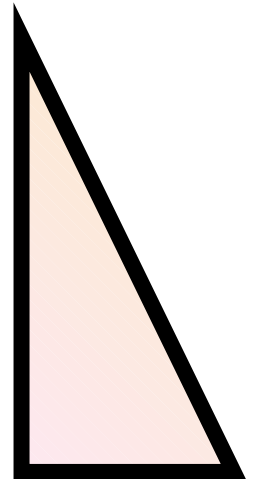
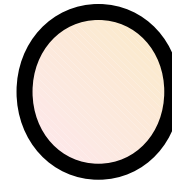
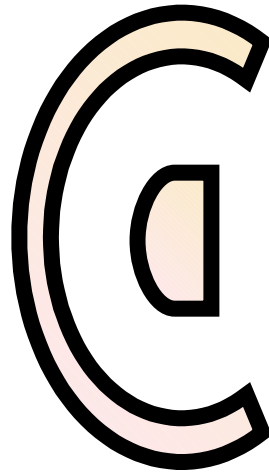
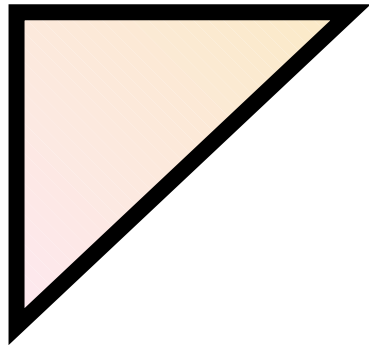
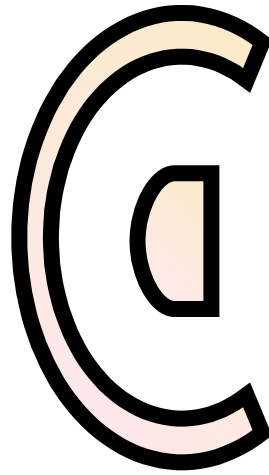

ASSOCIAZIONI DI IMMAGINI UGUALI O SIMILI
Associare le immagini uguali o simili.

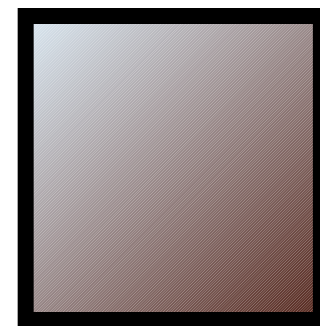
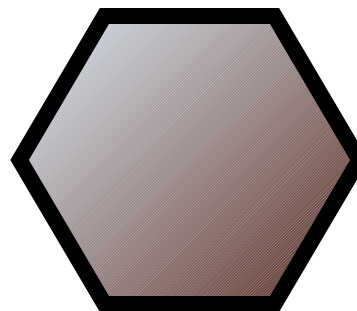
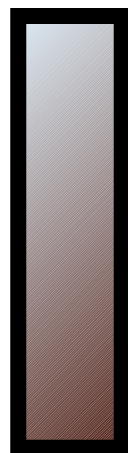
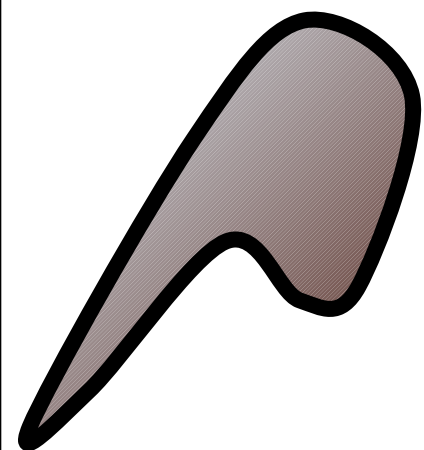
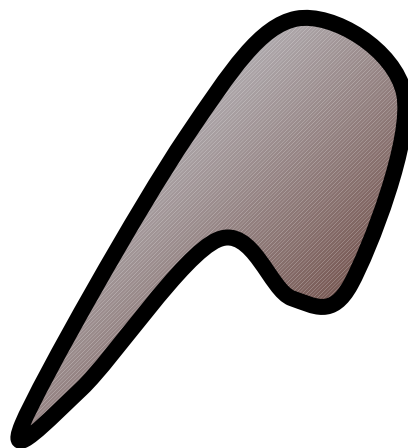

ASSOCIAZIONI DI IMMAGINI UGUALI O SIMILI
Associare le immagini uguali o simili.

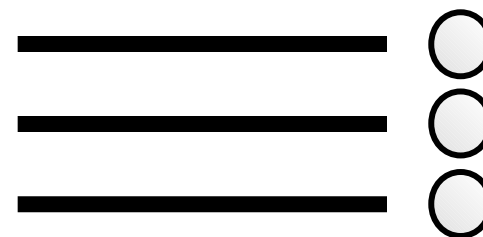
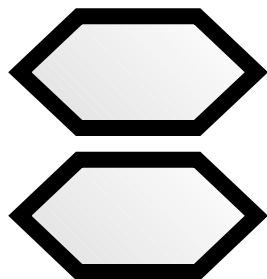
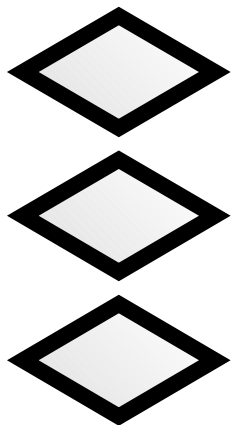
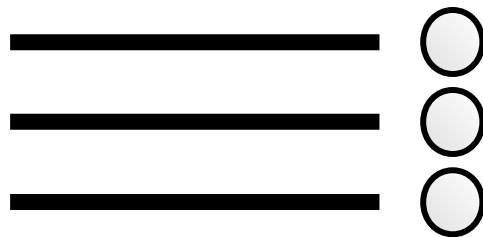

ASSOCIAZIONI DI IMMAGINI UGUALI O SIMILI
Associare le immagini uguali o simili.

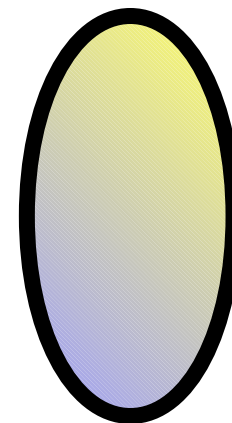
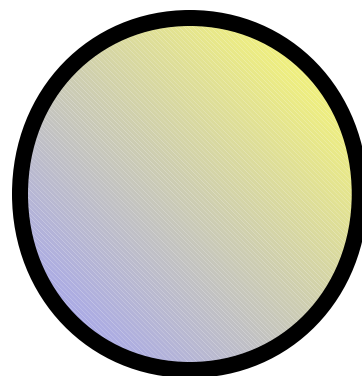
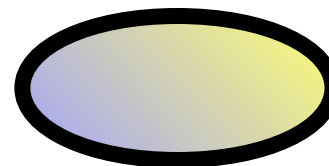
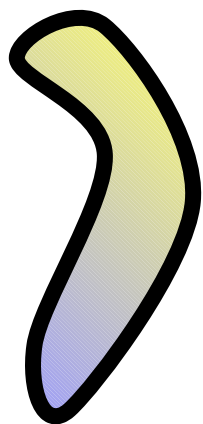
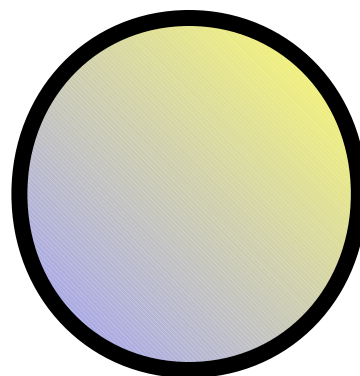

ASSOCIAZIONI DI IMMAGINI UGUALI O SIMILI
Associare le immagini uguali o simili.

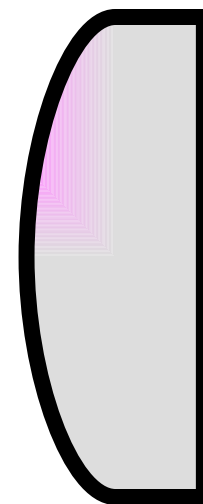
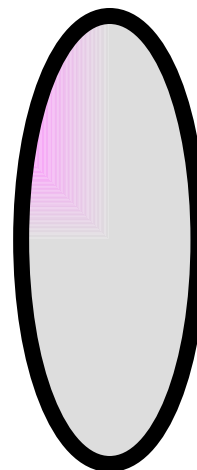
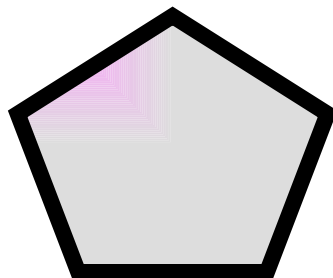
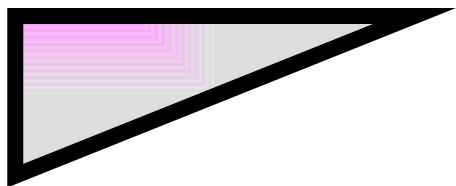
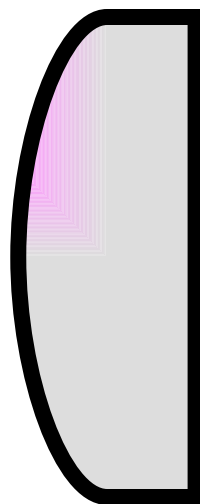

ASSOCIAZIONI DI IMMAGINI UGUALI O SIMILI
Associare le immagini uguali o simili.

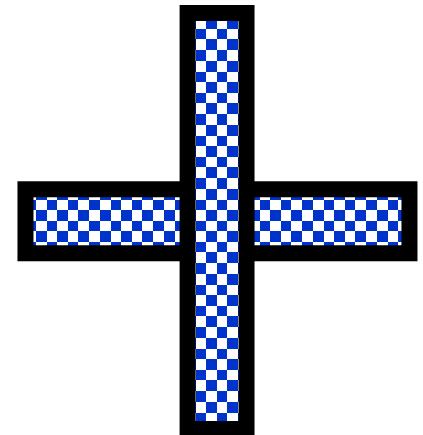
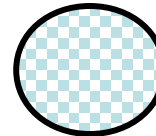

ASSOCIAZIONI DI IMMAGINI UGUALI O SIMILI
Associare le immagini uguali o simili.

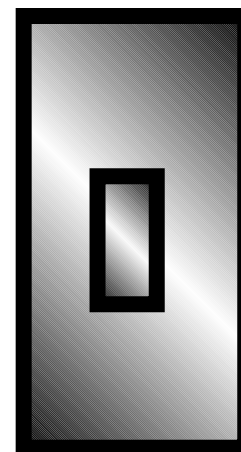
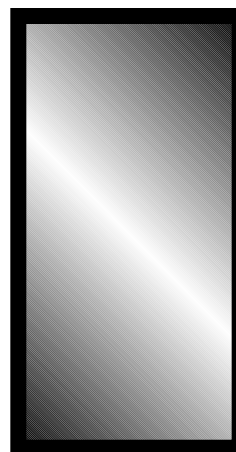
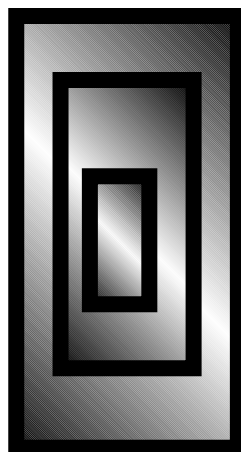
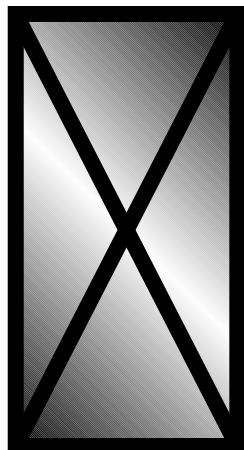
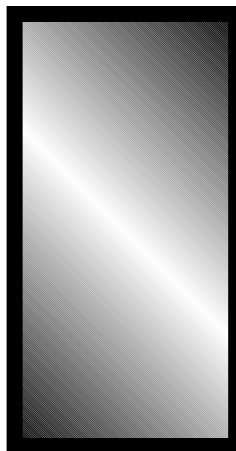

ASSOCIAZIONI DI IMMAGINI UGUALI O SIMILI
Associare le immagini uguali o simili.

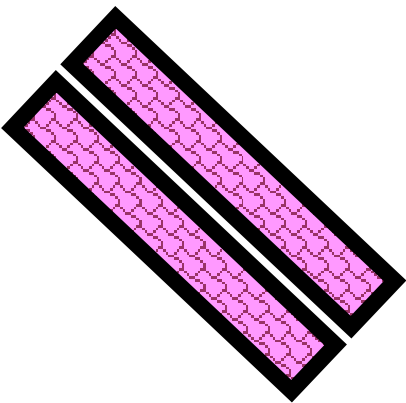
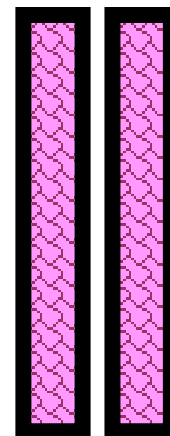
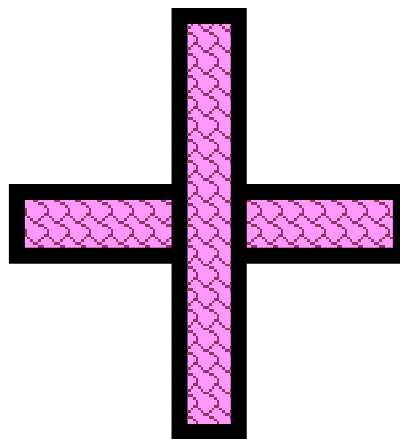
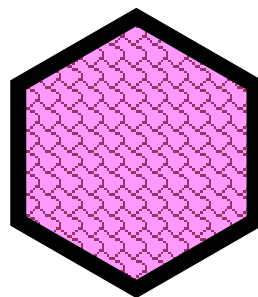
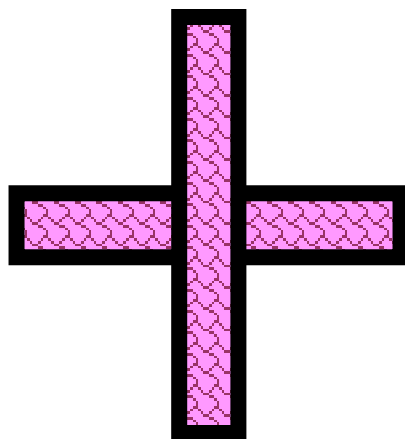

ASSOCIAZIONI DI IMMAGINI UGUALI O SIMILI
Associare le immagini uguali o simili.

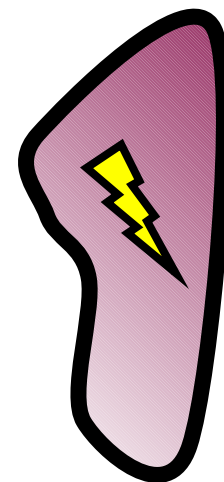
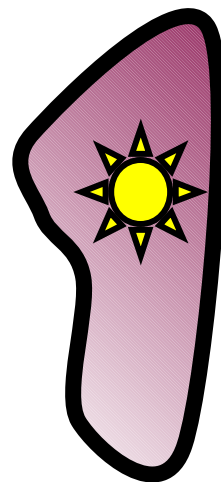
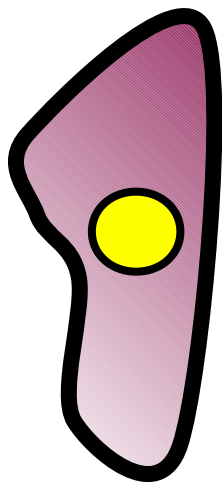
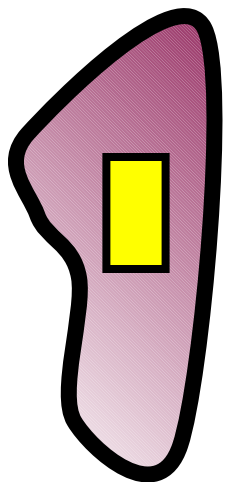
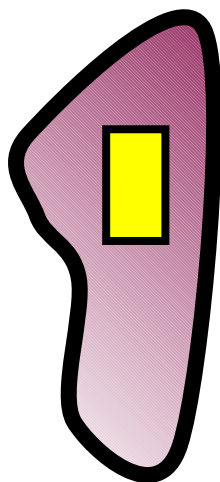

ASSOCIAZIONI DI IMMAGINI UGUALI O SIMILI
Associare le immagini uguali o simili.

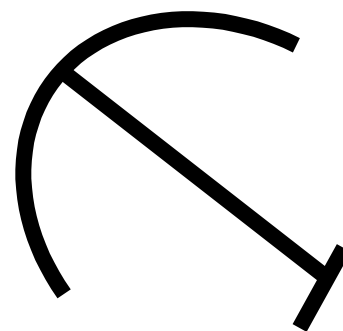
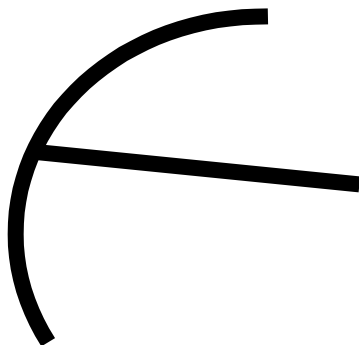
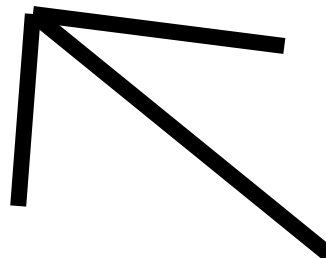
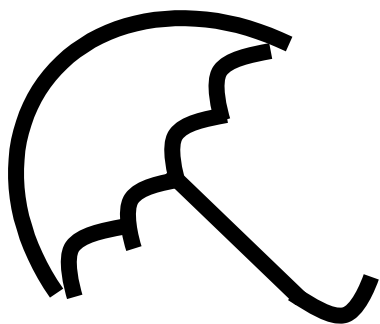
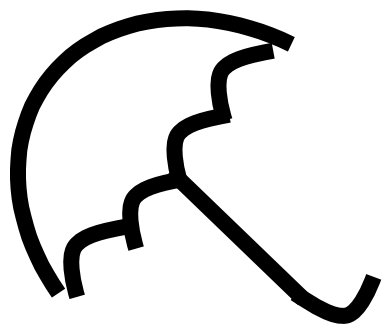

ASSOCIAZIONI DI IMMAGINI UGUALI O SIMILI
Associare le immagini uguali o simili.

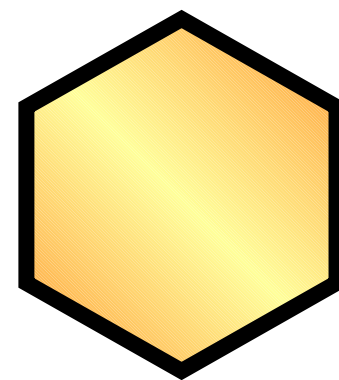
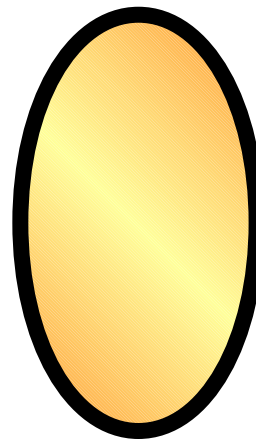
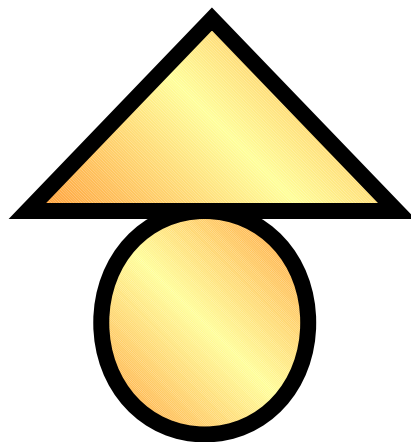
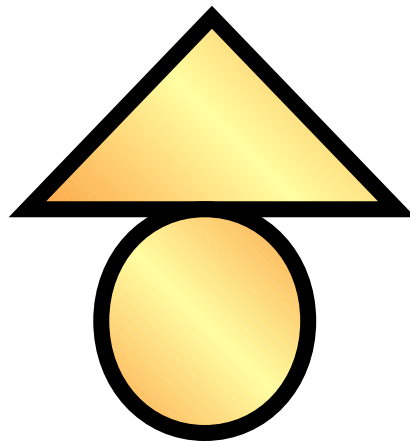

ASSOCIAZIONI DI IMMAGINI UGUALI O SIMILI
Associare le immagini uguali o simili.

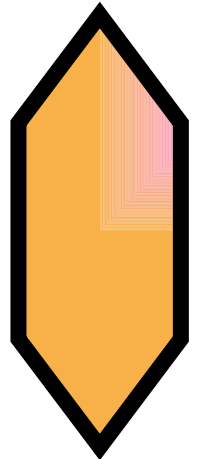
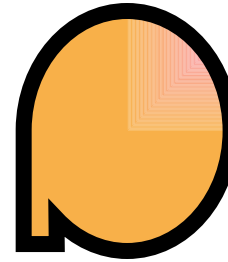
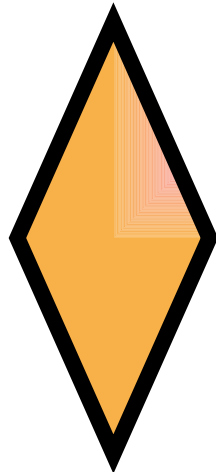
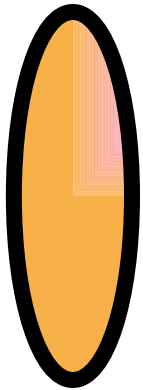
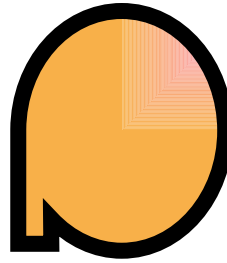

ASSOCIAZIONI DI IMMAGINI UGUALI O SIMILI
Associare le immagini uguali o simili.

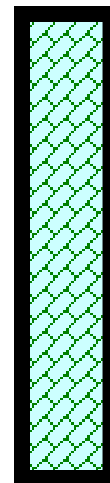
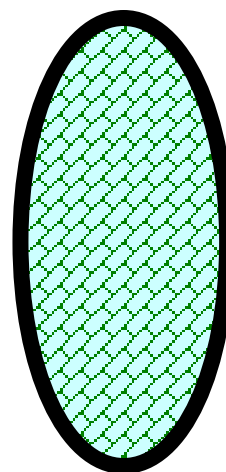
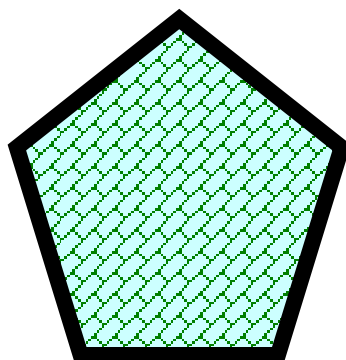
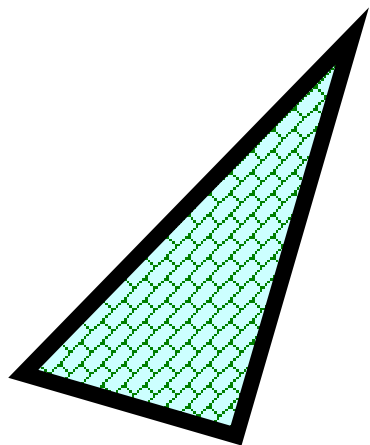
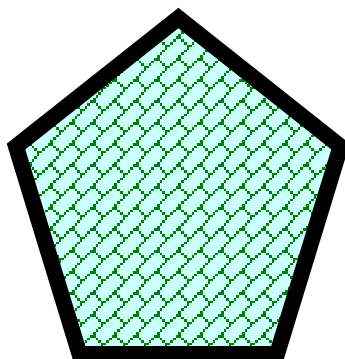

ASSOCIAZIONI DI IMMAGINI UGUALI O SIMILI
Associare le immagini uguali o simili.

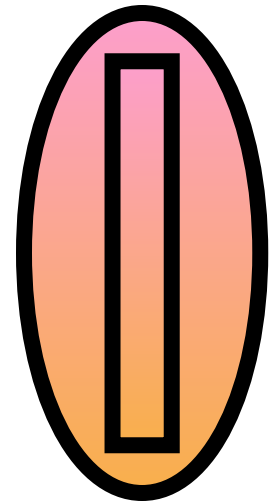
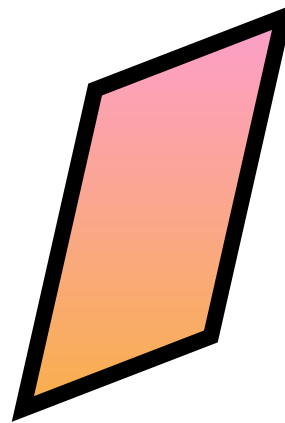
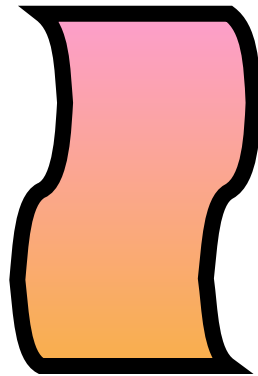
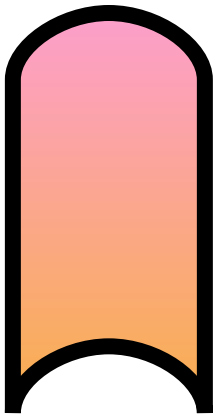
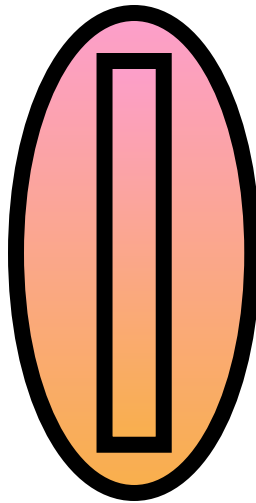

ASSOCIAZIONI DI IMMAGINI UGUALI O SIMILI
Associare le immagini uguali o simili.

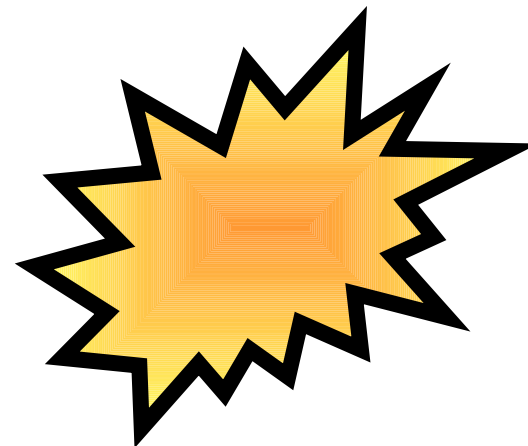
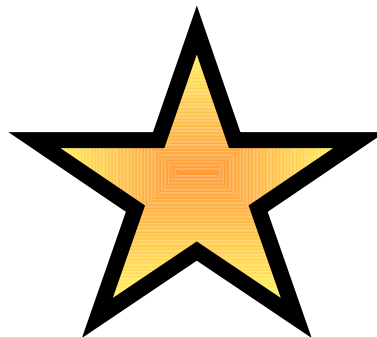
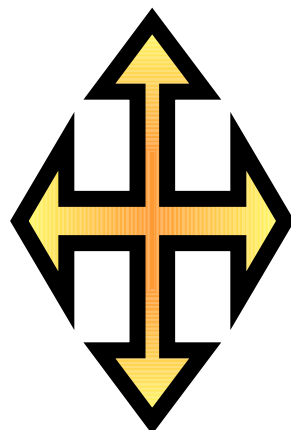
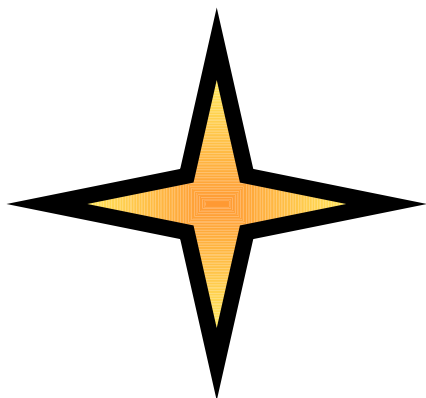
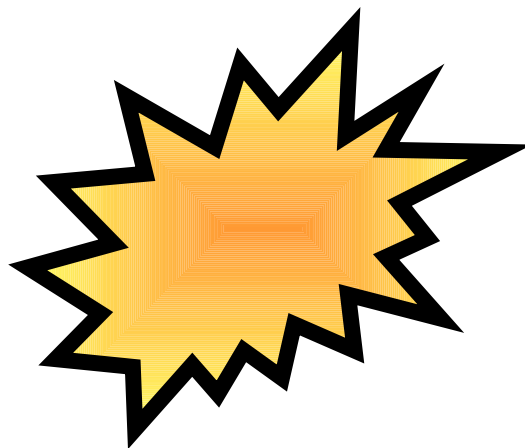

ASSOCIAZIONI DI IMMAGINI UGUALI O SIMILI
Associare le immagini uguali o simili.

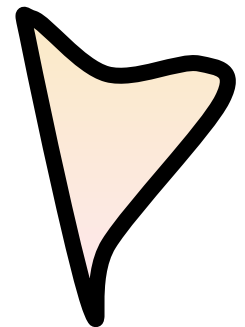
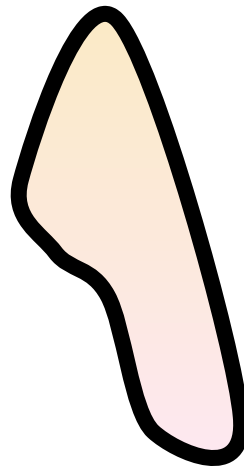
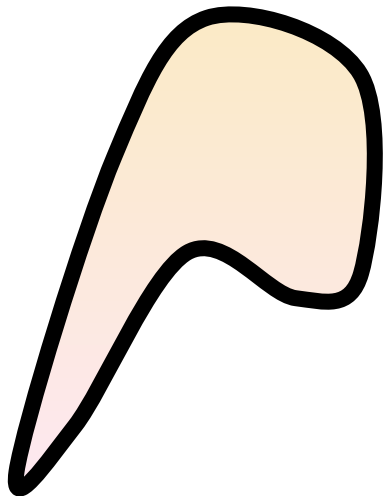

ASSOCIAZIONI DI IMMAGINI UGUALI O SIMILI
Associare le immagini uguali o simili.

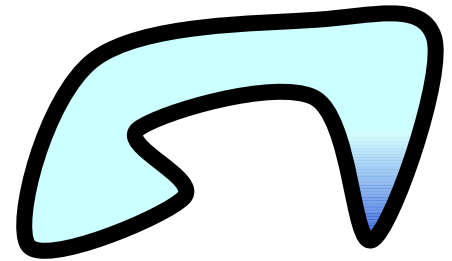
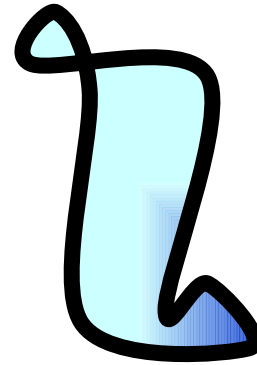
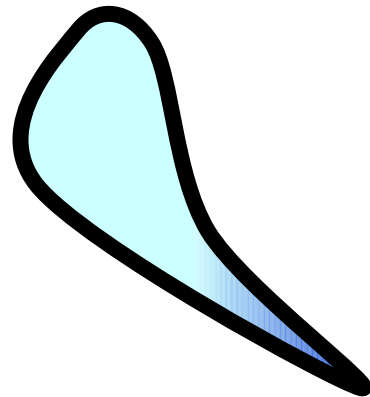
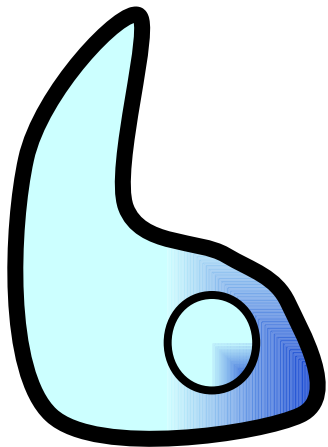
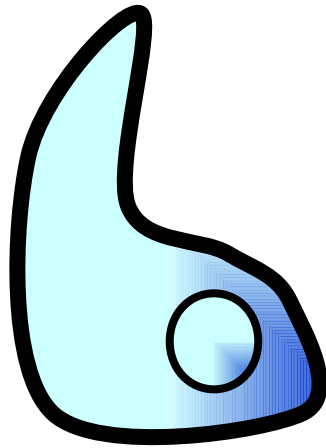

ASSOCIAZIONI DI IMMAGINI UGUALI O SIMILI
Associare le immagini uguali o simili.

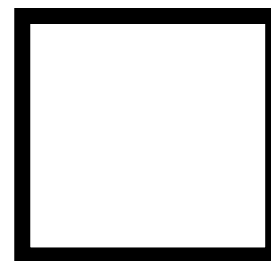
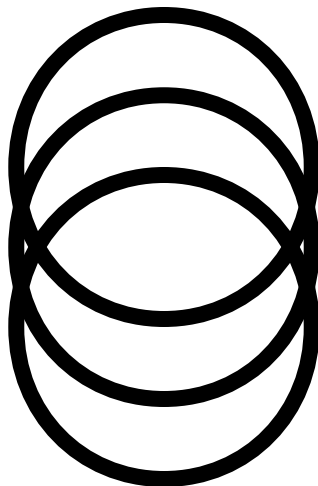
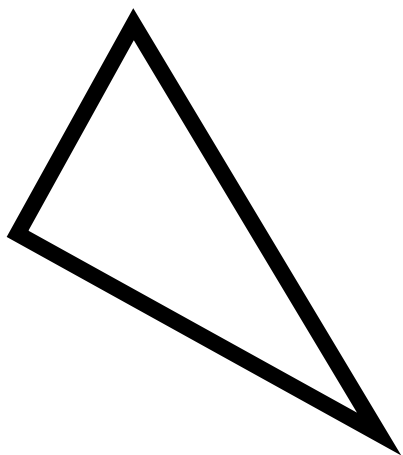
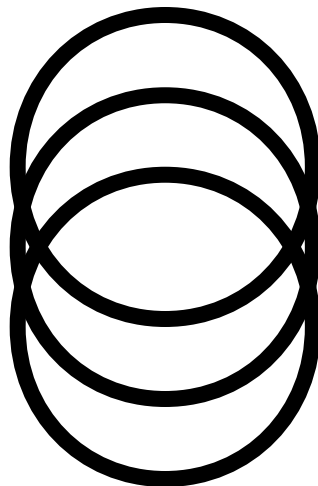

ASSOCIAZIONI DI IMMAGINI UGUALI O SIMILI
Associare le immagini uguali o simili.

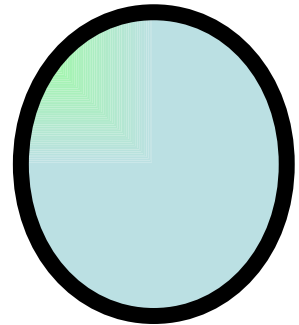
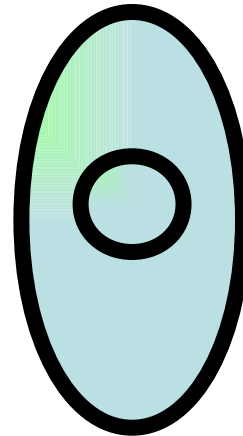
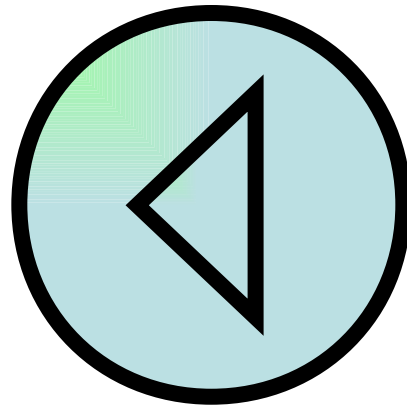
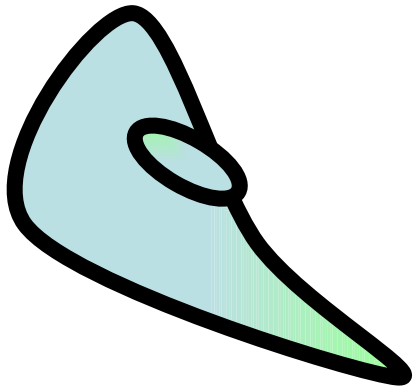
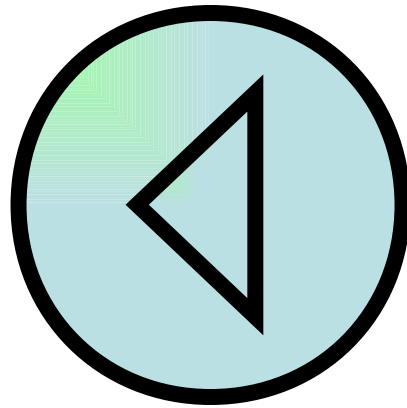

ASSOCIAZIONI DI IMMAGINI UGUALI O SIMILI
Associare le immagini uguali o simili.

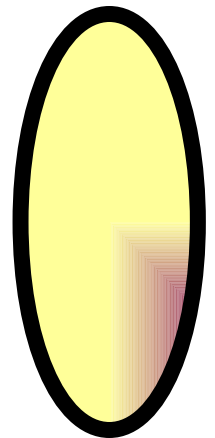
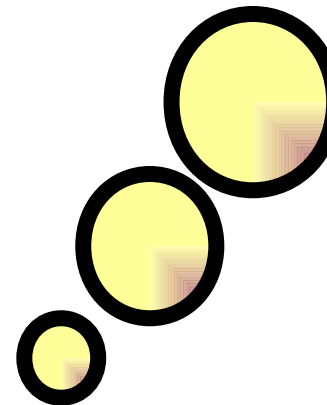
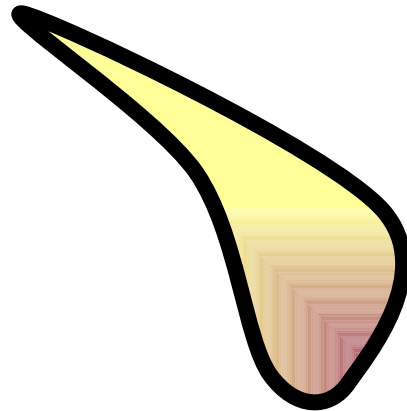
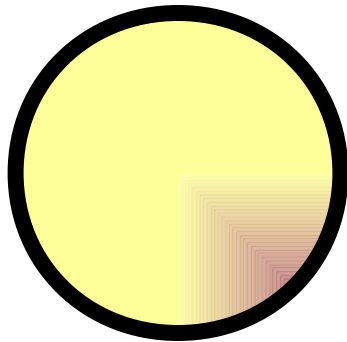
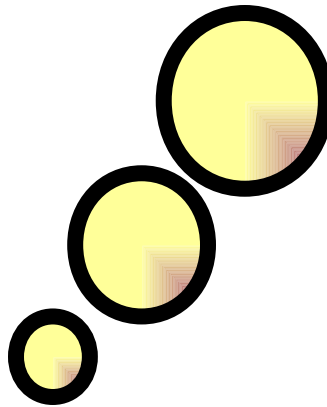

ASSOCIAZIONI DI IMMAGINI UGUALI O SIMILI
Associare le immagini uguali o simili.

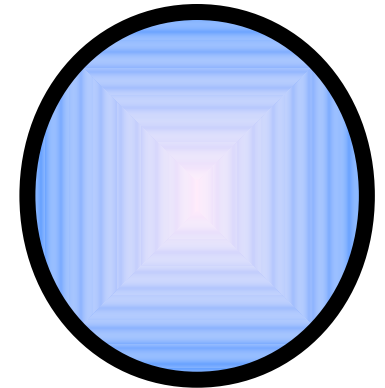
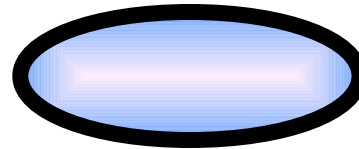
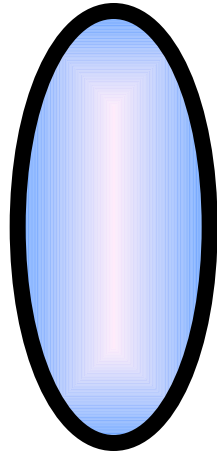
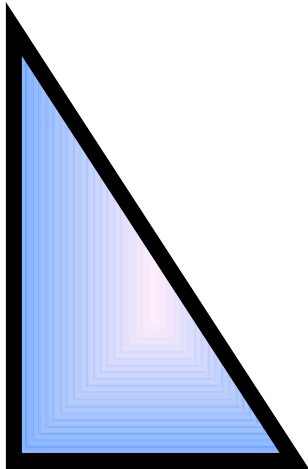
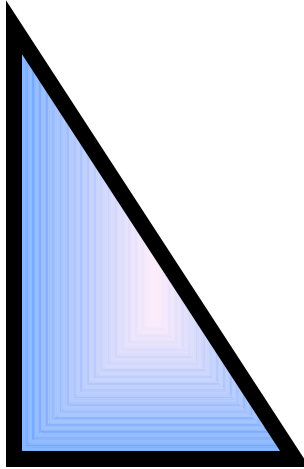

ASSOCIAZIONI DI IMMAGINI UGUALI O SIMILI
Associare le immagini uguali o simili.

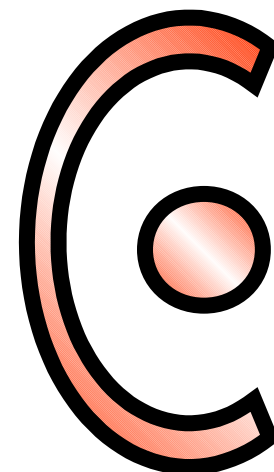
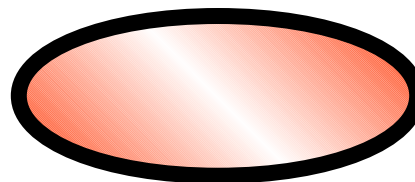
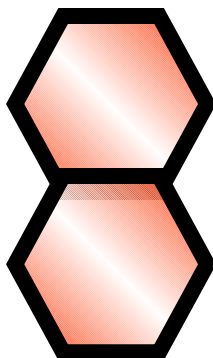
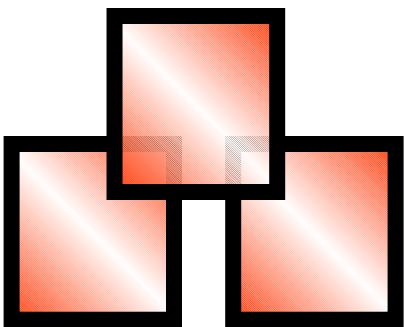
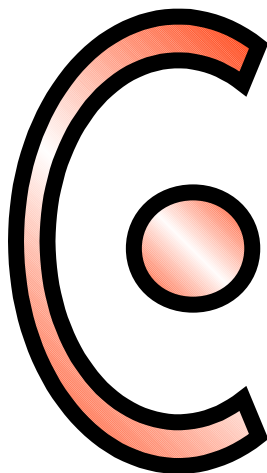

ASSOCIAZIONI DI IMMAGINI UGUALI O SIMILI
Associare le immagini uguali o simili.

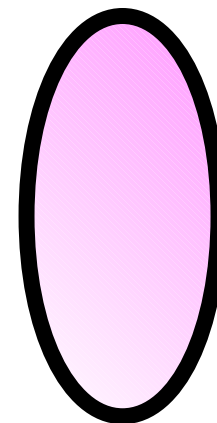
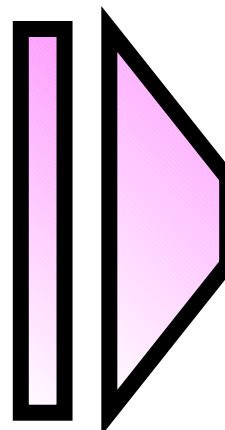
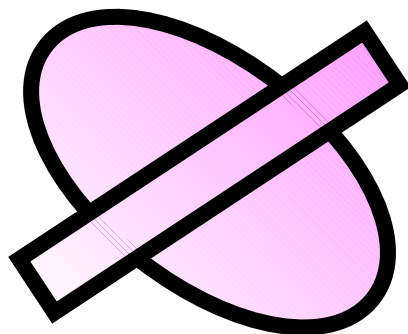
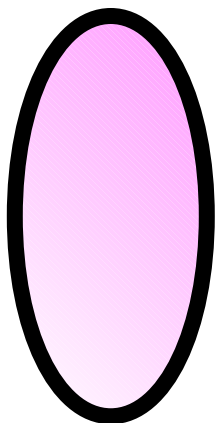
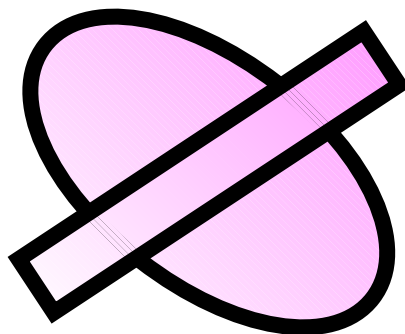

ASSOCIAZIONI DI IMMAGINI UGUALI O SIMILI
Associare le immagini uguali o simili.

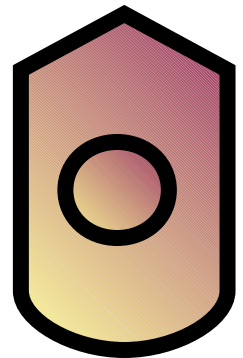
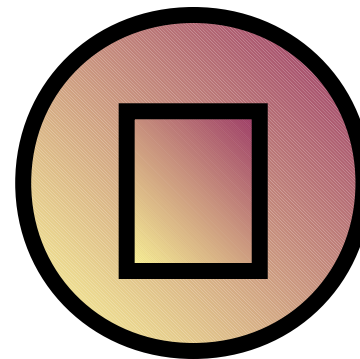
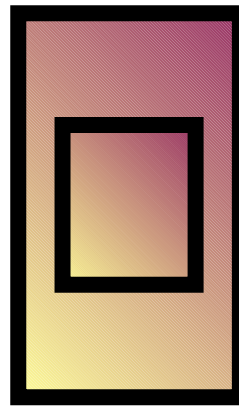
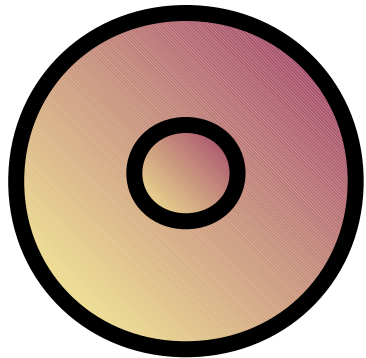
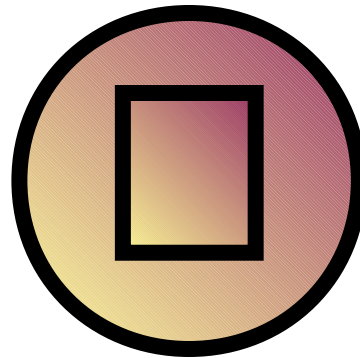

ASSOCIAZIONI DI IMMAGINI UGUALI O SIMILI
Associare le immagini uguali o simili.

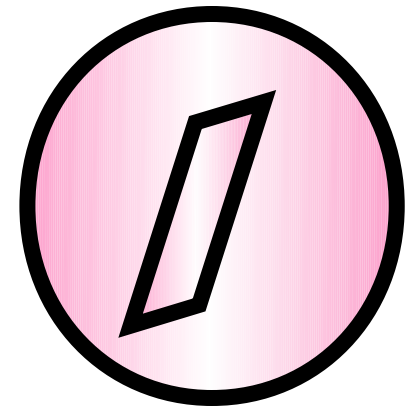
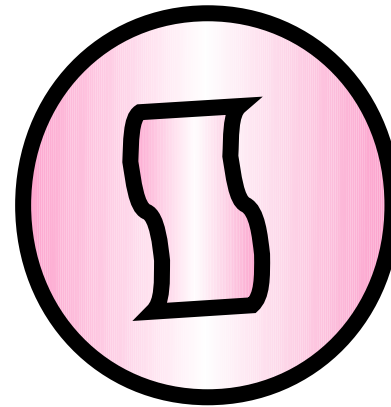
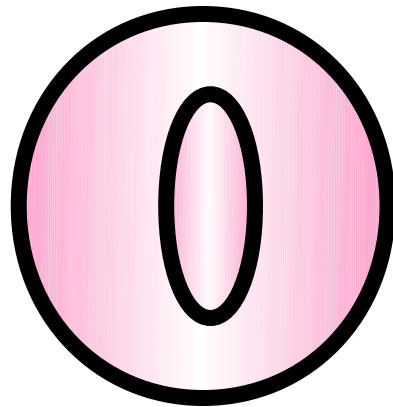
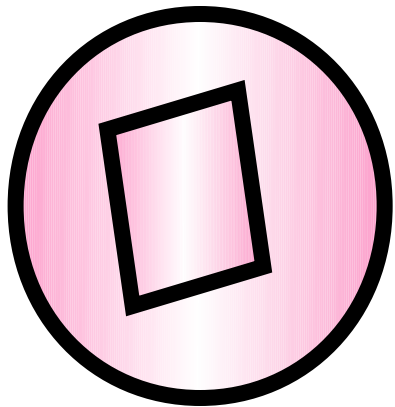
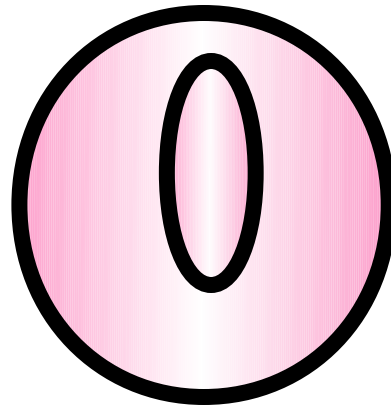

ASSOCIAZIONI DI IMMAGINI UGUALI O SIMILI
Associare le immagini uguali o simili.

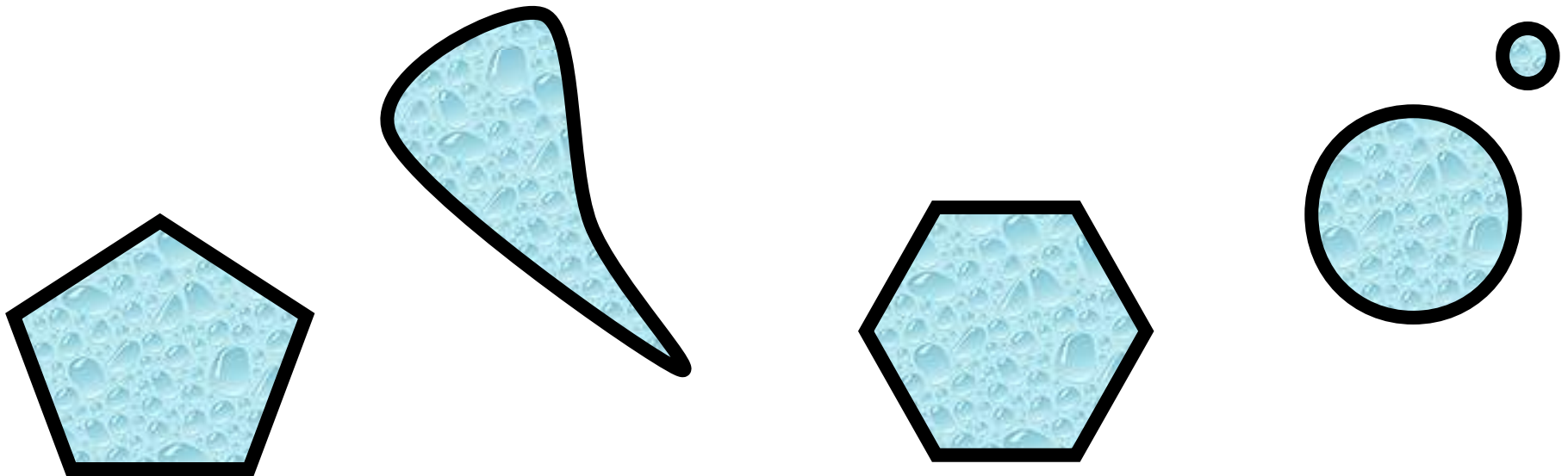
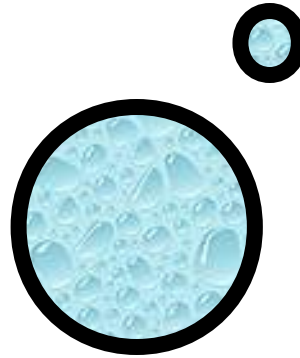

ASSOCIAZIONI DI IMMAGINI UGUALI O SIMILI
Associare le immagini uguali o simili.

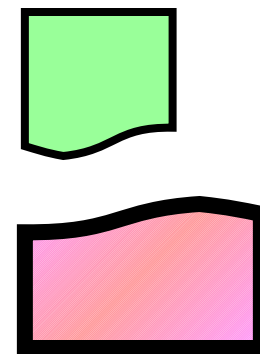
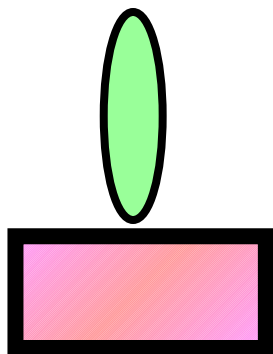
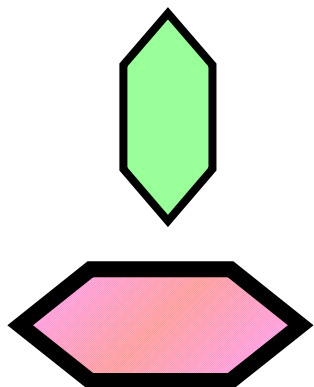
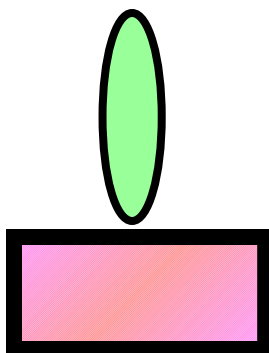

ASSOCIAZIONI DI IMMAGINI UGUALI O SIMILI
Associare le immagini uguali o simili.

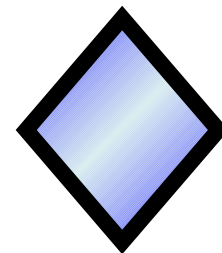
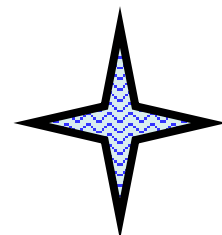
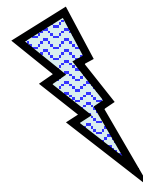
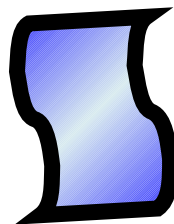
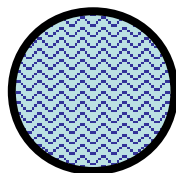
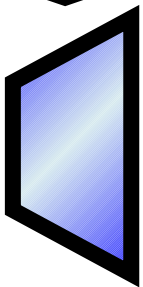
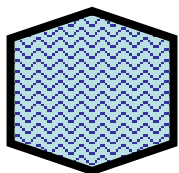
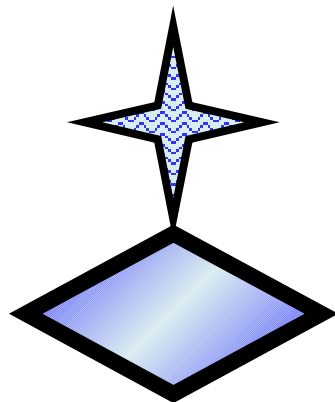

ASSOCIAZIONI DI IMMAGINI UGUALI O SIMILI
Associare le immagini uguali o simili.

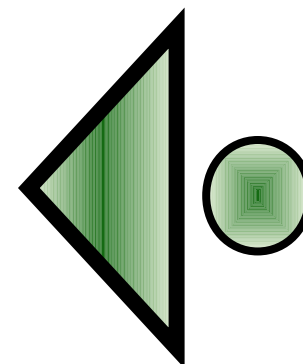
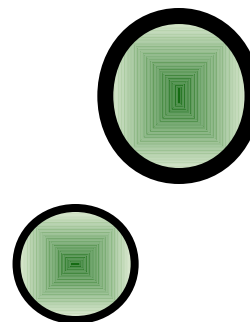
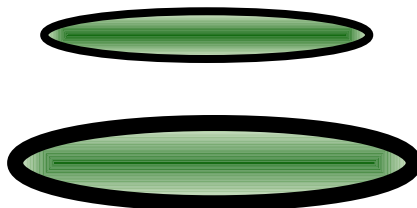
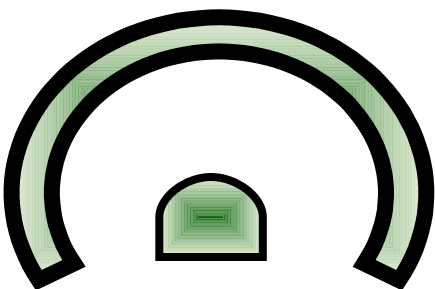
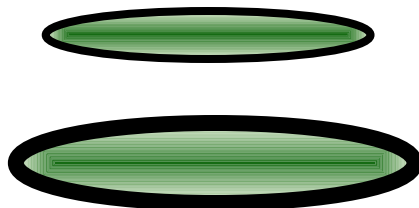

ASSOCIAZIONI DI IMMAGINI UGUALI O SIMILI
Associare le immagini uguali o simili.

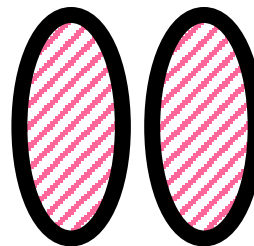
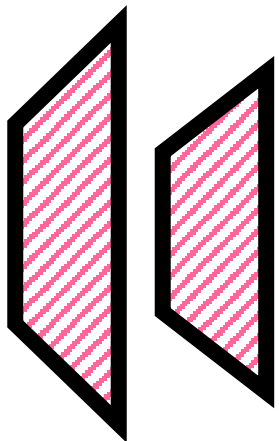
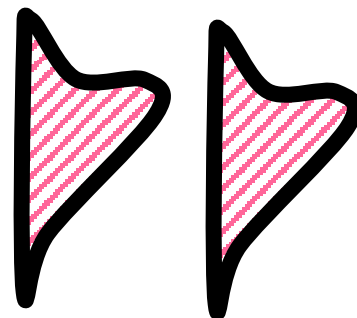
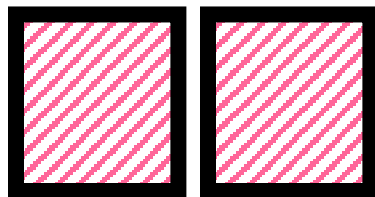
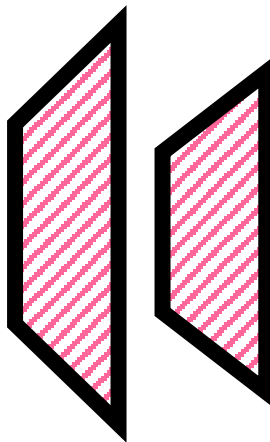

ASSOCIAZIONI DI IMMAGINI UGUALI O SIMILI
Associare le immagini uguali o simili.

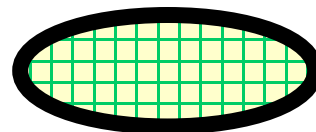
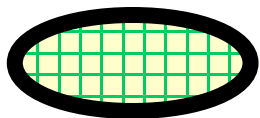
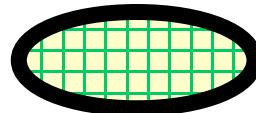
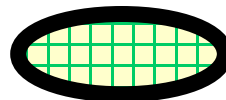
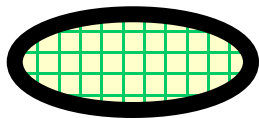
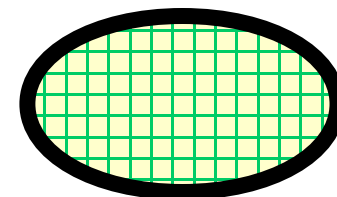
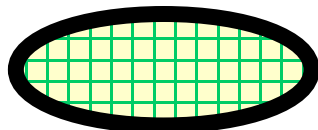
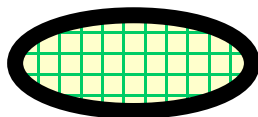
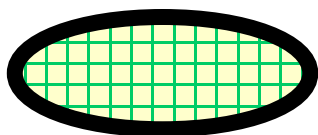

ASSOCIAZIONI DI IMMAGINI UGUALI O SIMILI
Associare le immagini uguali o simili.

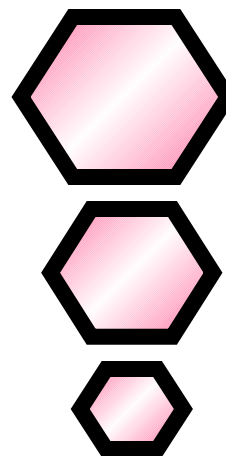
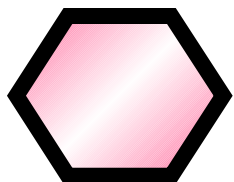
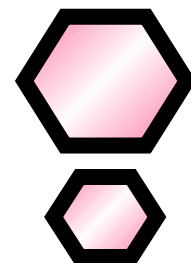
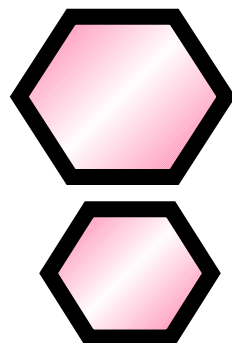
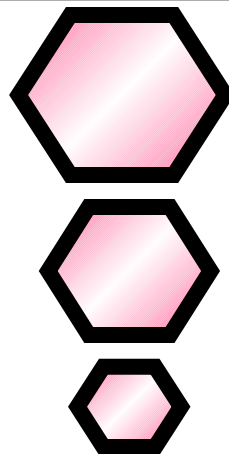

ASSOCIAZIONI DI IMMAGINI UGUALI O SIMILI
Associare le immagini uguali o simili.

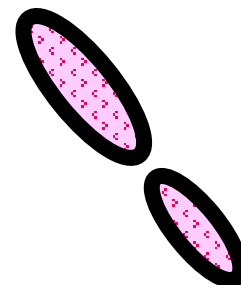
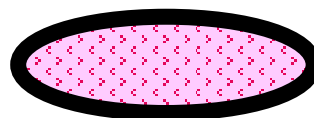
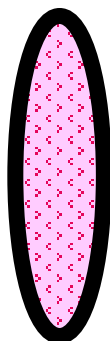
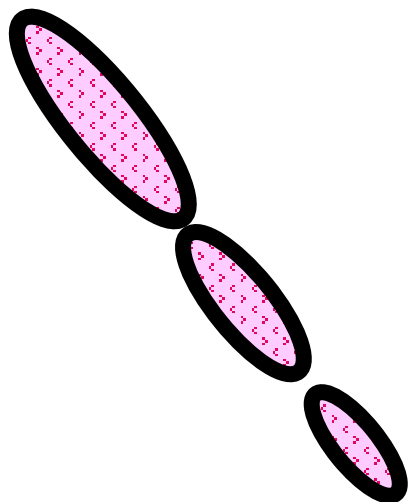
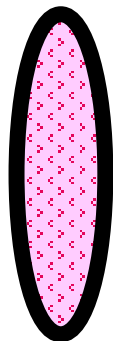

ASSOCIAZIONI DI IMMAGINI UGUALI O SIMILI
Associare le immagini uguali o simili.

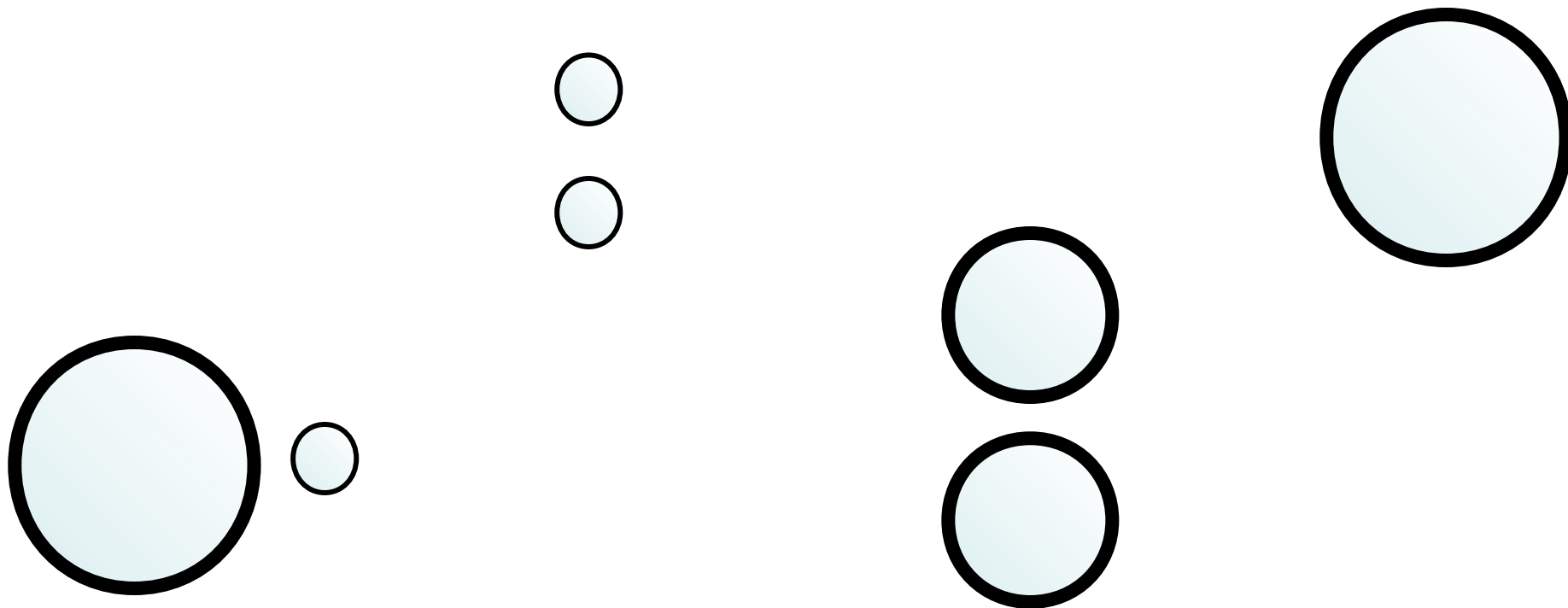
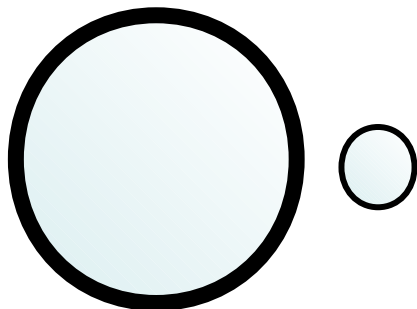

ASSOCIAZIONI DI IMMAGINI UGUALI O SIMILI
Associare le immagini uguali o simili.

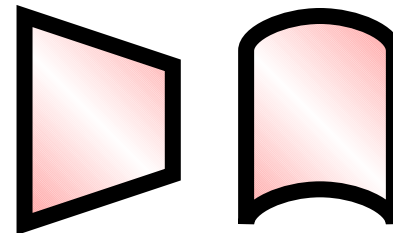
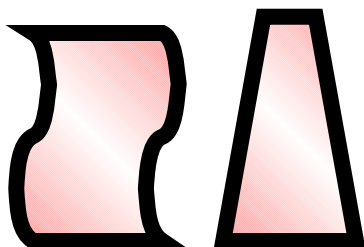
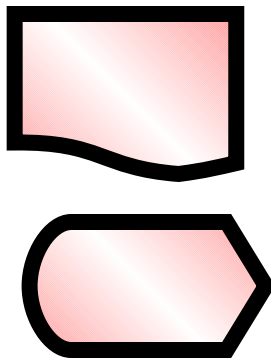
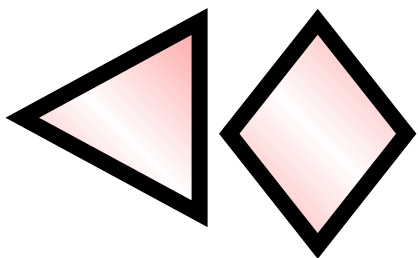
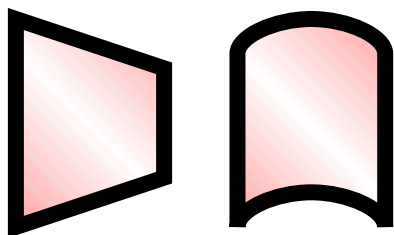

ASSOCIAZIONI DI IMMAGINI UGUALI O SIMILI
Associare le immagini uguali o simili.

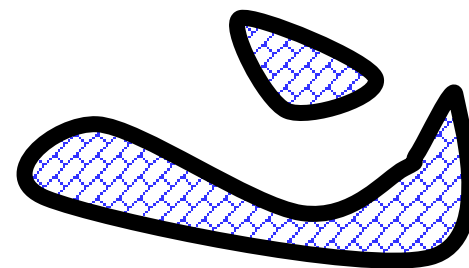
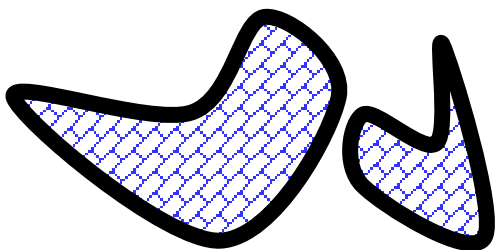
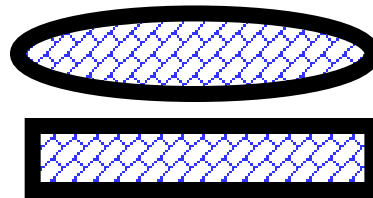
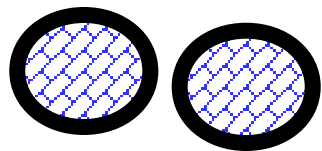
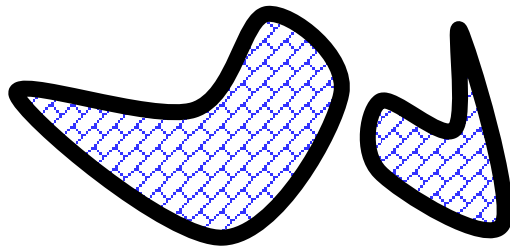

ASSOCIAZIONI DI IMMAGINI UGUALI O SIMILI
Associare le immagini uguali o simili.

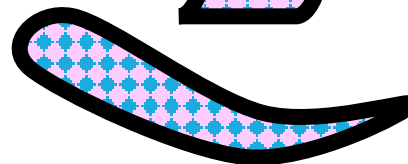
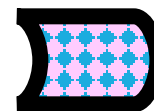
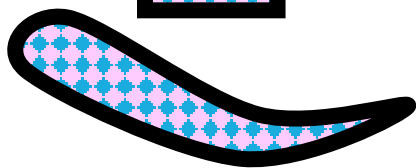
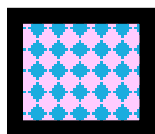
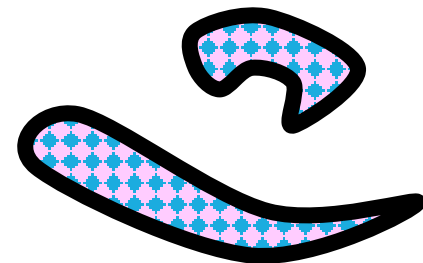
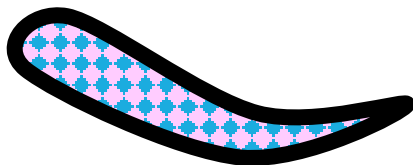
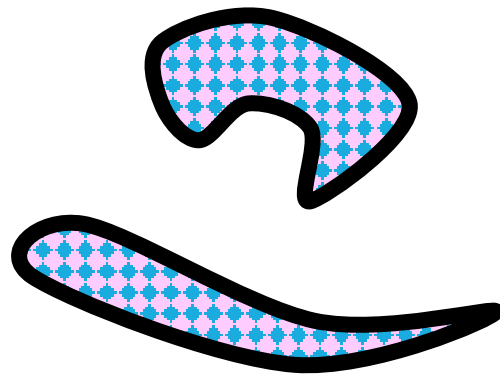

ASSOCIAZIONI DI IMMAGINI UGUALI O SIMILI
Associare le immagini uguali o simili.

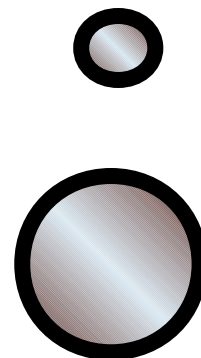
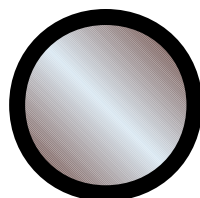
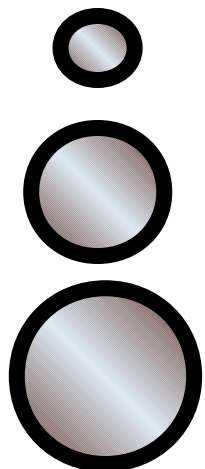
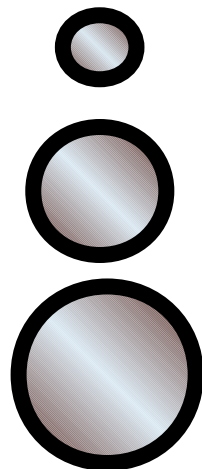

ASSOCIAZIONI DI IMMAGINI UGUALI O SIMILI
Associare le immagini uguali o simili.

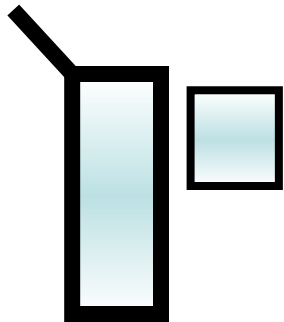
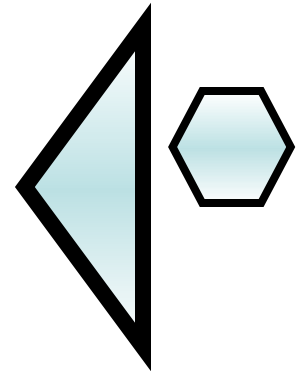
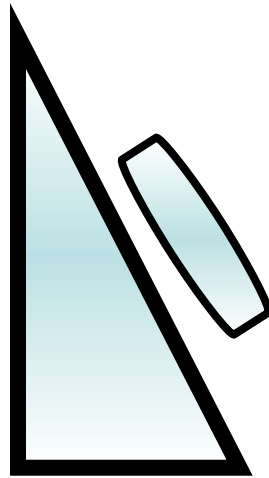
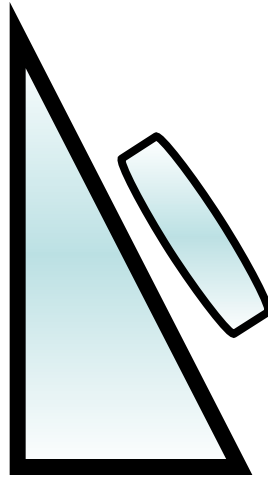

ASSOCIAZIONI DI IMMAGINI UGUALI O SIMILI
Associare le immagini uguali o simili.

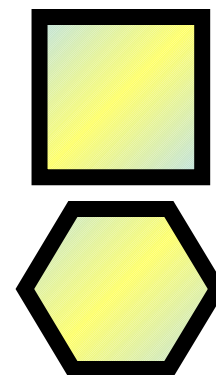
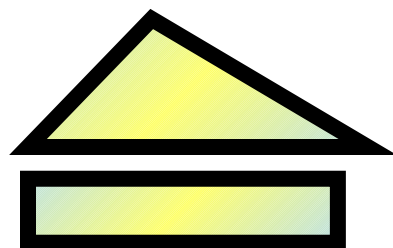
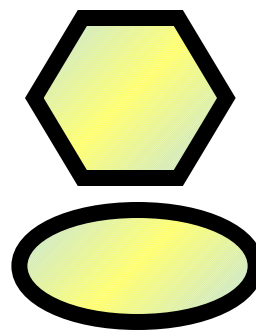
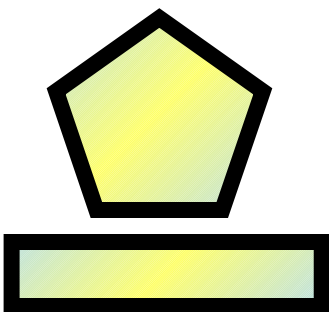
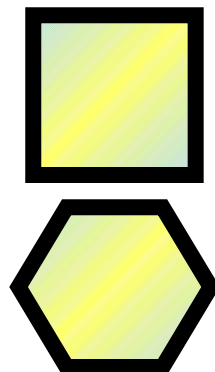

ASSOCIAZIONI DI IMMAGINI UGUALI O SIMILI
Associare le immagini uguali o simili.

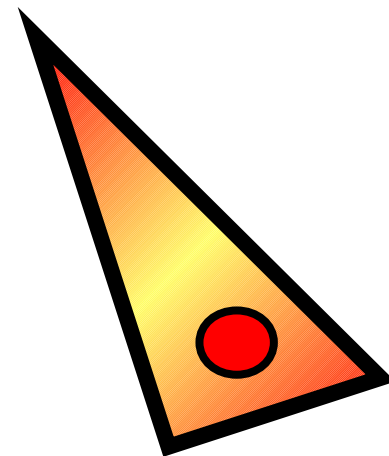
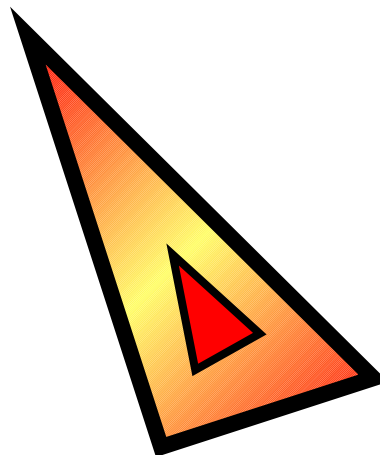
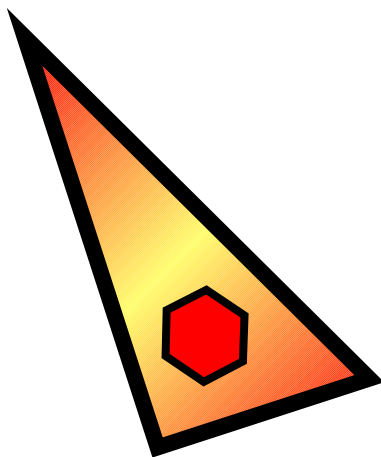
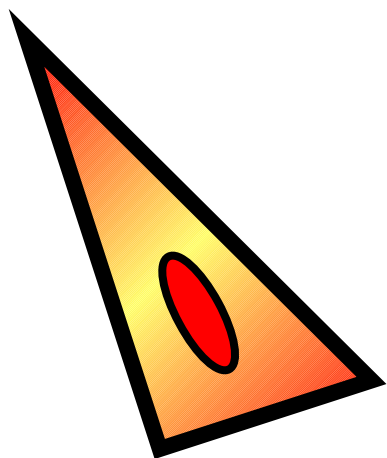
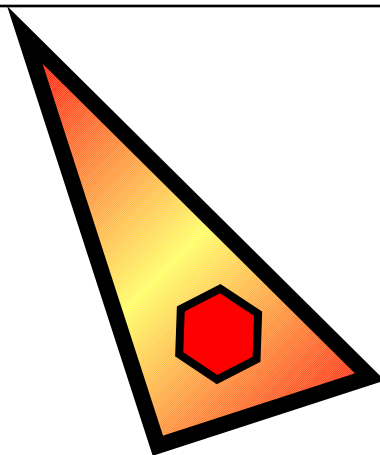

ASSOCIAZIONI DI IMMAGINI UGUALI O SIMILI
Associare le immagini uguali o simili.

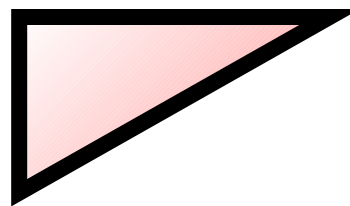
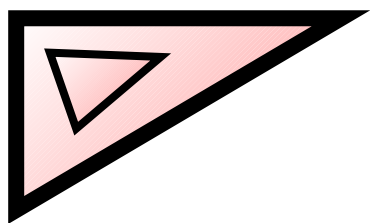
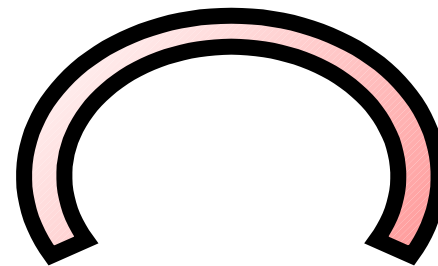
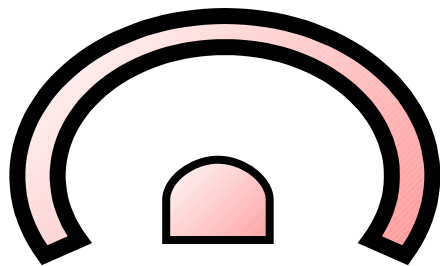
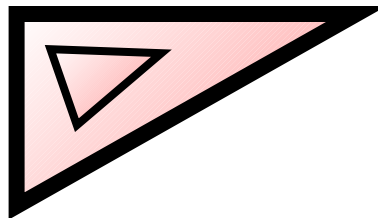

ASSOCIAZIONI DI IMMAGINI UGUALI O SIMILI
Associare le immagini uguali o simili.

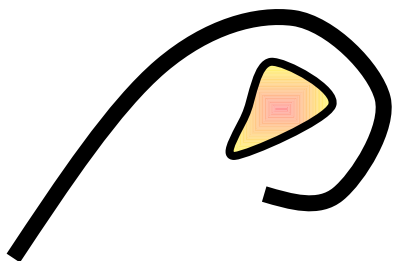

ASSOCIAZIONI DI IMMAGINI UGUALI O SIMILI
Associare le immagini uguali o simili.

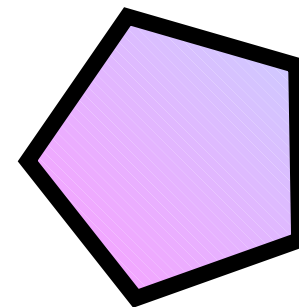
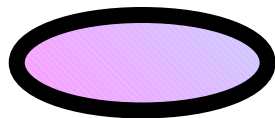
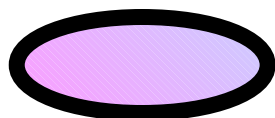
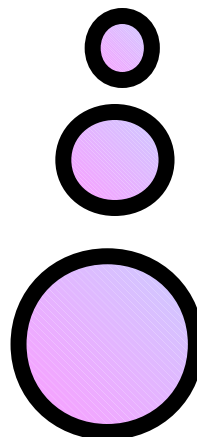
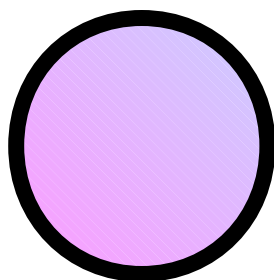
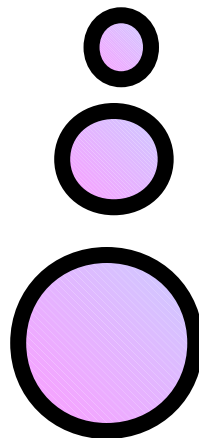

ASSOCIAZIONI DI IMMAGINI UGUALI O SIMILI
Associare le immagini uguali o simili.

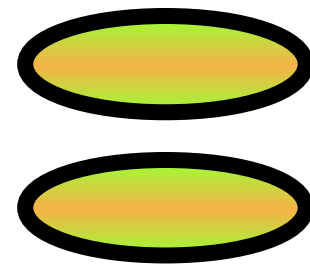
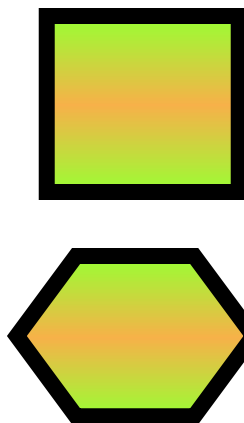
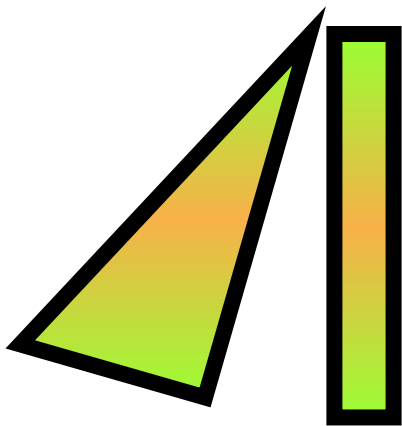
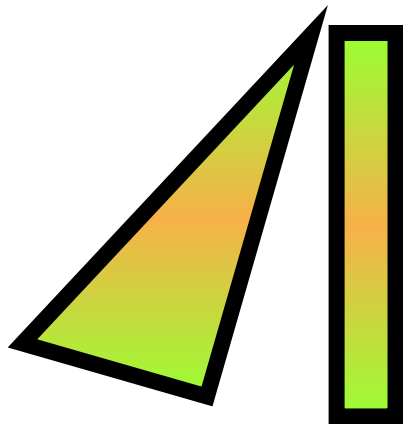

ASSOCIAZIONI DI IMMAGINI UGUALI O SIMILI
Associare le immagini uguali o simili.

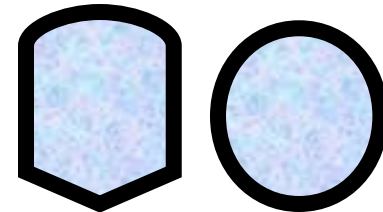
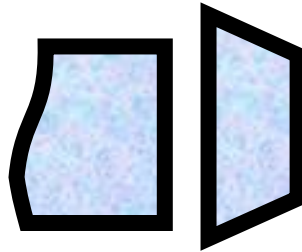
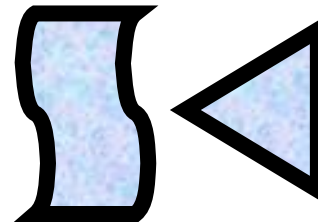
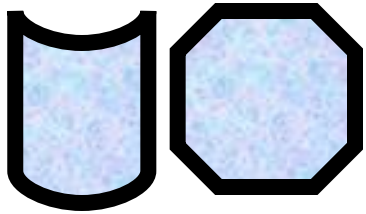
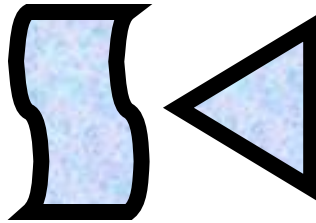

ASSOCIAZIONI DI IMMAGINI UGUALI O SIMILI
Associare le immagini uguali o simili.

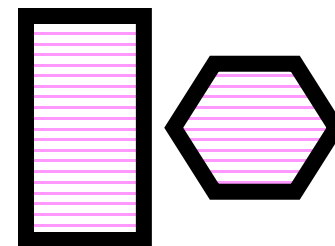
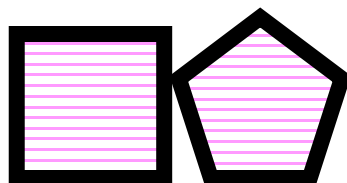
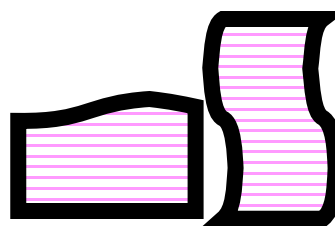
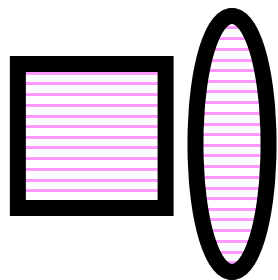
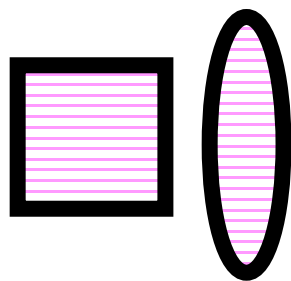

ASSOCIAZIONI DI IMMAGINI UGUALI O SIMILI
Associare le immagini uguali o simili.

“ VOGLIA DI CRESCERE ”

PROGRAMMA BASE PER LO SVILUPPO LOGICO E COGNITIVO

LINGUAGGIO: ASSOCIAZIONI VERBALI

LINGUAGGIO : ASSOCIAZIONI VERBALI

In queste schede sono presenti tre brevi frasi da collegare per il loro significato a tre immagini.

- Lo scopo è quello di stimolare la comprensione dei nomi e delle espressioni linguistiche presenti nella frase, ciò porterà, naturalmente, a una maggiore ricchezza del vocabolario del bambino.
- Nel momento in cui vengono richieste l'uso, la funzione, il significato o le caratteristiche dell'immagine presentata, abbiamo la possibilità di aiutare il bambino a sviluppare sia gli elementi culturali che il linguaggio espressivo.

UTILIZZAZIONE

Primo fase

Per stimolare la comprensione verbale si leggerà la prima frase ed il bambino dovrà indicare l'immagine a cui si riferisce, lo stesso si farà con le successive.

Seconda fase

In un secondo tempo per stimolare l'espressione verbale facendo osservare l'immagine disegnata e rispettando il contenuto delle frasi scritte, si chiederà l'uso, la funzione, o qualche caratteristica dell'oggetto rappresentato.

Naturalmente per i bambini che sanno leggere si copriranno le frasi scritte per evitare che possano decifrare le risposte.

ETÀ DI RIFERIMENTO

Sviluppo linguistico e intellettuale di almeno tre anni.

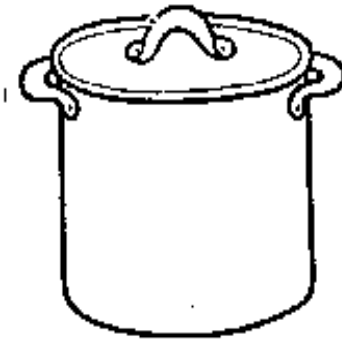
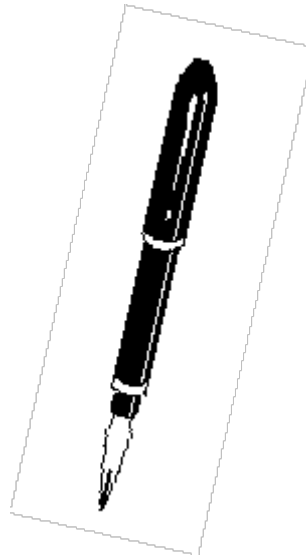

- Serve per scrivere i compiti.
- Serve per cuocere i cibi.
- Serve per afferrare e stringere i fili.

ASSOCIAZIONI VERBALI

Far associare ogni frase all'immagine corrispondente.

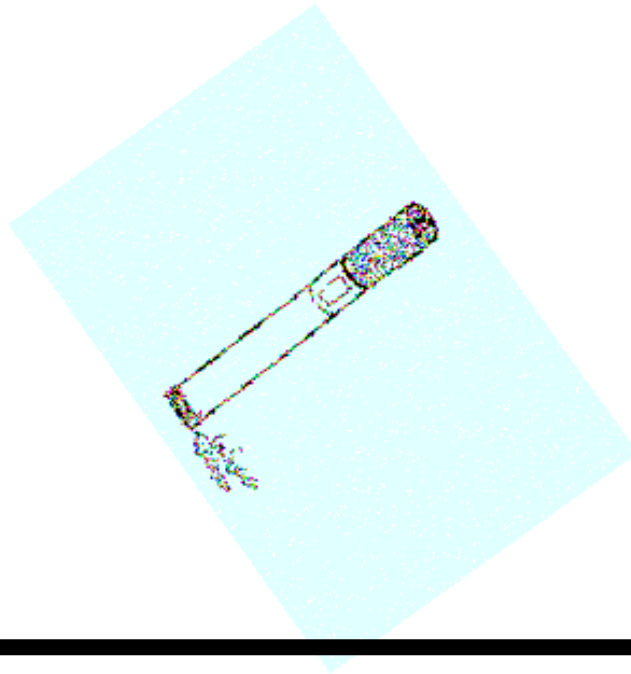
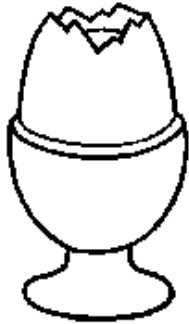

- Si fuma.
- Si mangia.
- Si succhia.

ASSOCIAZIONI VERBALI

Far associare ogni frase all'immagine corrispondente.

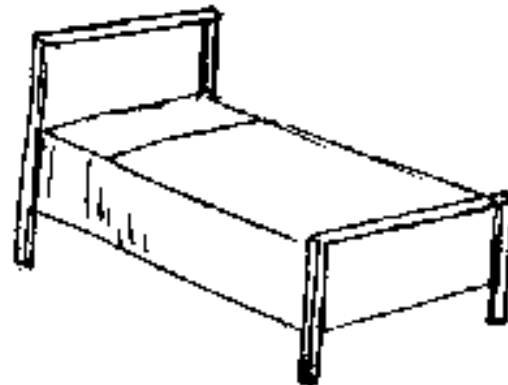
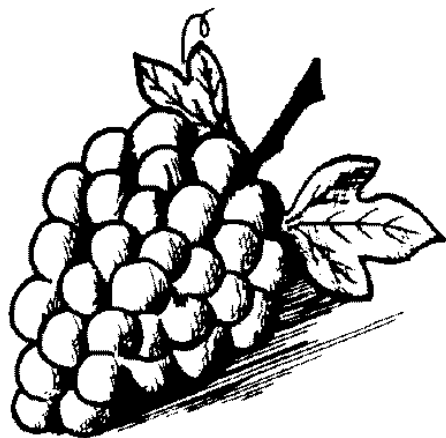

- Si beve.
- Si mangia.
- Si dorme.

ASSOCIAZIONI VERBALI

Far associare ogni frase all'immagine corrispondente.

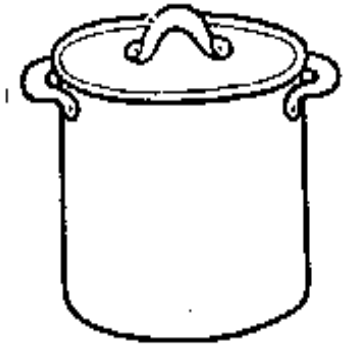
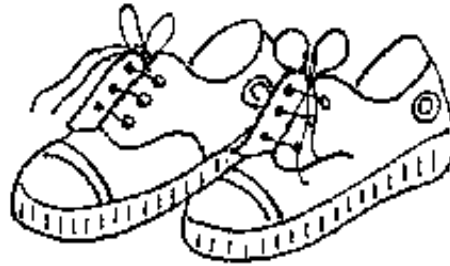

- Si cuoce con ...
 - Si legge il ...
 - Si cammina con ...

ASSOCIAZIONI VERBALI

Far associare ogni frase all'immagine corrispondente.



- Per mangiare.
- Per vestire.
- Per riposare.

ASSOCIAZIONI VERBALI

Far associare ogni frase all'immagine corrispondente.

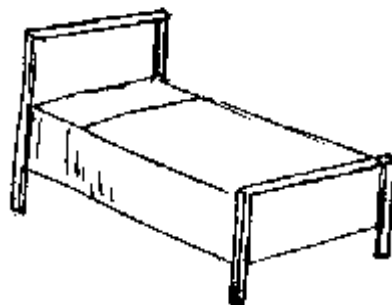
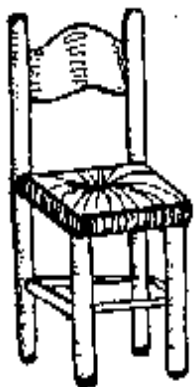

- Si usa per dormire.
 - Si usano per mangiare.
 - Si usa per sedersi.

ASSOCIAZIONI VERBALI

Far associare ogni frase all'immagine corrispondente.

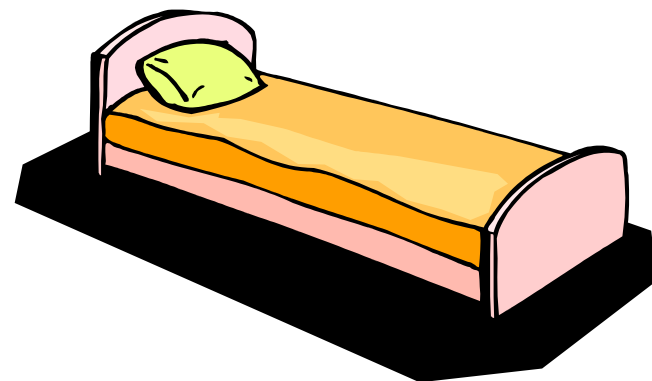
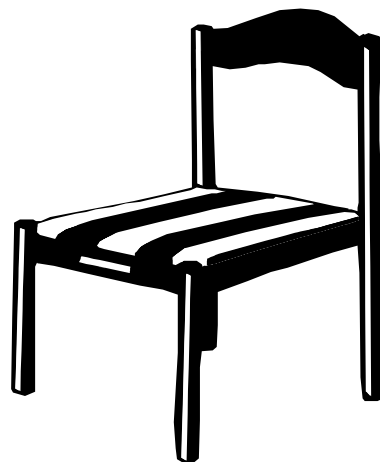

- Materasso e cuscino per ...
 - Una tavola per ...
 - Quattro gambe e una spalliera per ...

ASSOCIAZIONI VERBALI

Far associare ogni frase all'immagine corrispondente.



- Ha la punta per scrivere.
- Ha la cruna per cucire.
- Hanno il calice per bere.

ASSOCIAZIONI VERBALI

Far associare ogni frase all'immagine corrispondente.

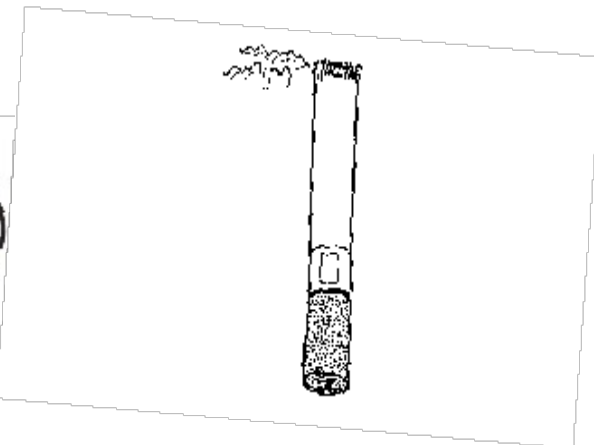
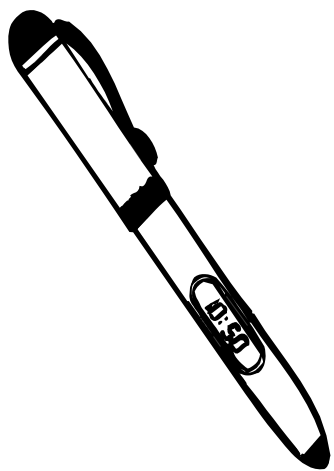

- Si scrive con ...
 - Si fuma con ...
 - Si beve con ...

ASSOCIAZIONI VERBALI

Far associare ogni frase all'immagine corrispondente.

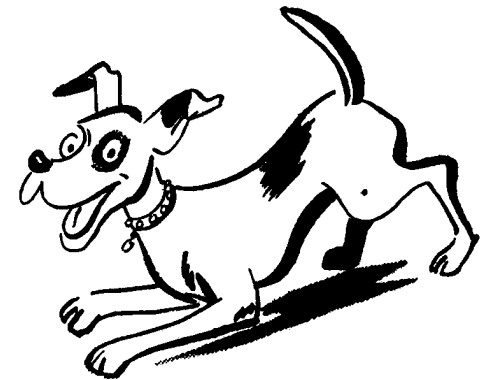
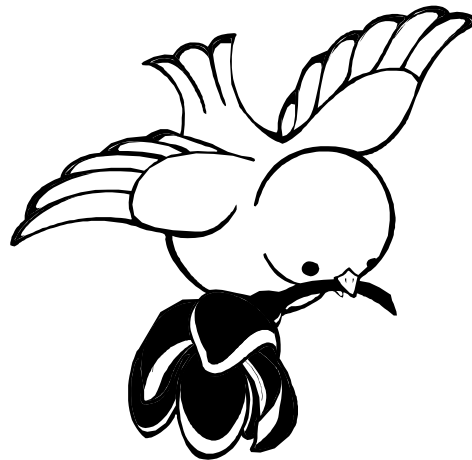

- E' coperto di piume, saltella sui rami, fa le uova nel nido.
Ha il muso allungato, abbaia e dorme nella cuccia.
Vola leggera nell'aria e si posa sui fiori.

ASSOCIAZIONI VERBALI

Far associare ogni frase all'immagine corrispondente.

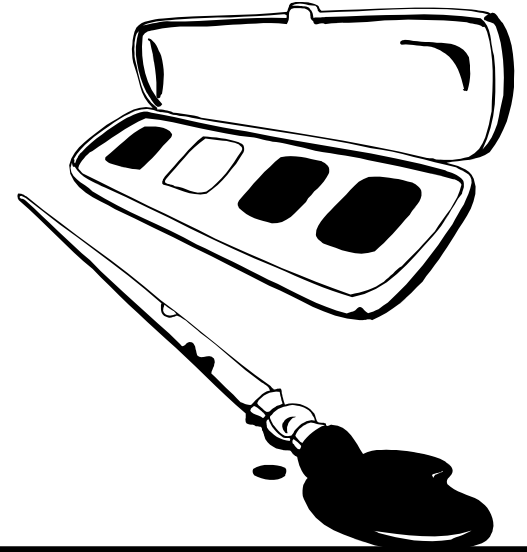
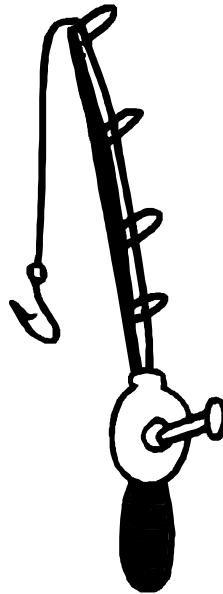
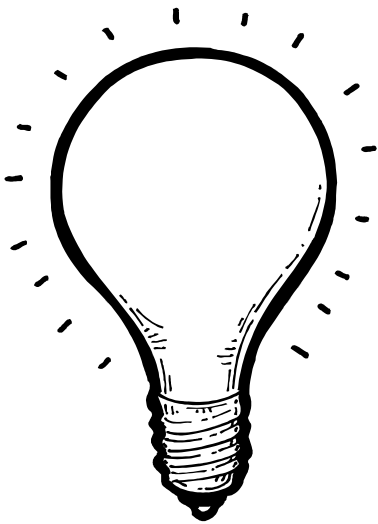

- Colori e pennelli per dipingere.
- Canna e filo per pescare.
- Filamento e bulbo per illuminare.

ASSOCIAZIONI VERBALI

Far associare ogni frase all'immagine corrispondente.



- La casa del cane.
- La casa del bimbo.
- La casa dell'uccello.

ASSOCIAZIONI VERBALI

Far associare ogni frase all'immagine corrispondente.

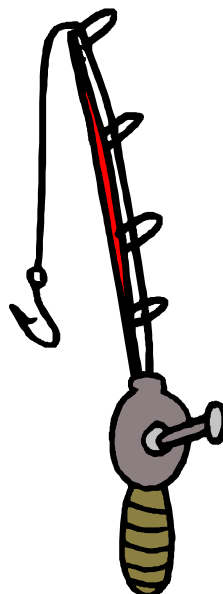
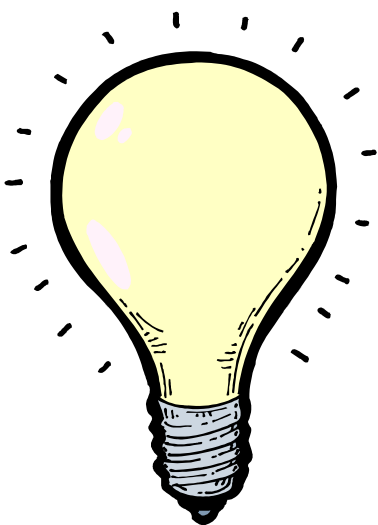

- La usa il pescatore.
 - La usa l'elettricista.
 - La usa il pittore.

ASSOCIAZIONI VERBALI

Far associare ogni frase all'immagine corrispondente.



- Lo ripara l'orologiaio.
- L'accorda il musicista.
- La ripara il meccanico.

ASSOCIAZIONI VERBALI

Far associare ogni frase all'immagine corrispondente.



- E' un neonato e piange.
- E' un adulto e lavora.
- E' una bambina e gioca.

ASSOCIAZIONI VERBALI

Far associare ogni frase all'immagine corrispondente.

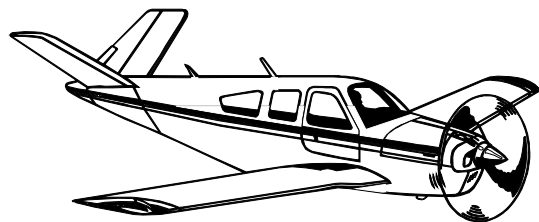
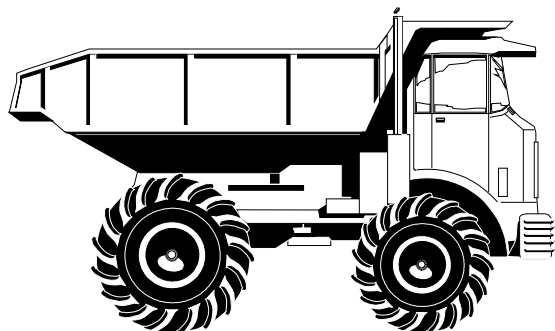
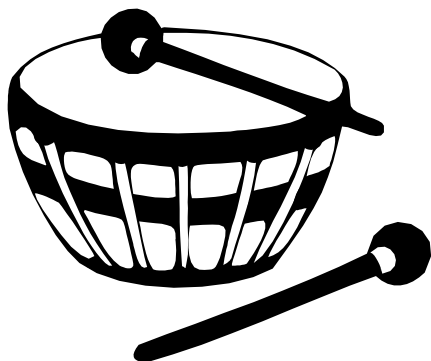

- Per volare.
- Per suonare.
- Per trasportare.

ASSOCIAZIONI VERBALI

Far associare ogni frase all'immagine corrispondente.



- Contiene i fiori.
- Contiene i colori.
- Contiene l'acqua.

ASSOCIAZIONI VERBALI

Far associare ogni frase all'immagine corrispondente.

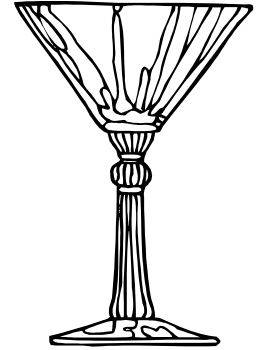
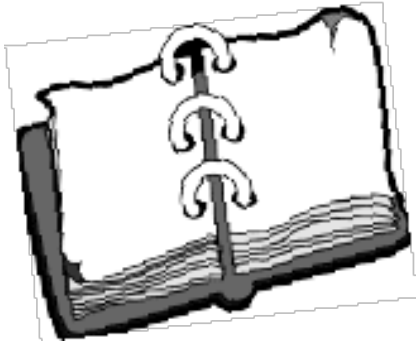

- E' di vetro
- E' di carta
- E' di gomma

ASSOCIAZIONI VERBALI

Far associare ogni frase all'immagine corrispondente.

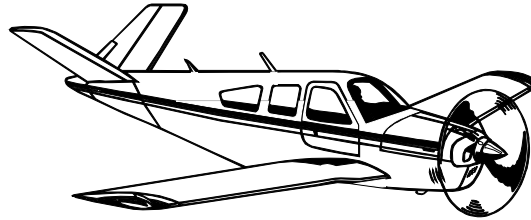

- E' pesante e vola
 - E' leggera e vola
 - E' pesante ed affonda

ASSOCIAZIONI VERBALI

Far associare ogni frase all'immagine corrispondente.

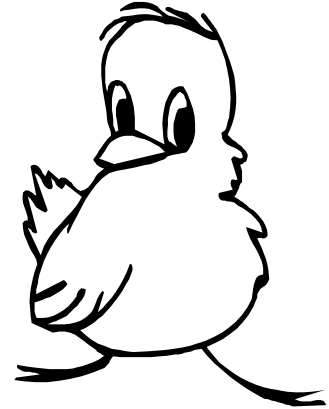
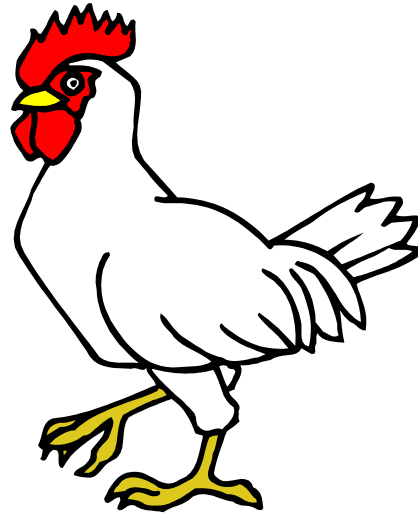

- Vive nel nido e mangia i semini.
- Razzola nell'aia e mangia il granturco.
- Vive nel canile e spolpa le ossa.

ASSOCIAZIONI VERBALI

Far associare ogni frase all'immagine corrispondente.

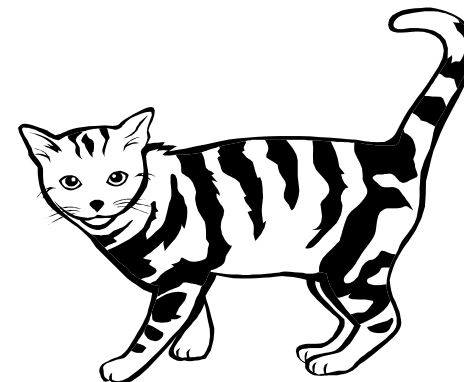
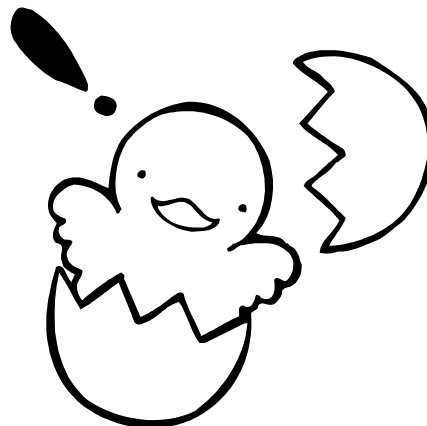
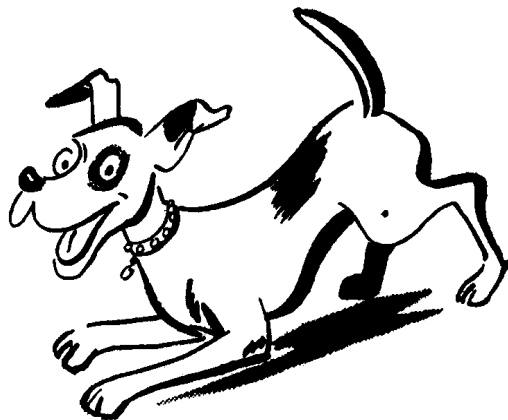

- Fa pio ... pio il ...
 - Fa miao ... il ...
 - Fa bau ... bau il ...

ASSOCIAZIONI VERBALI

Far associare ogni frase all'immagine corrispondente.

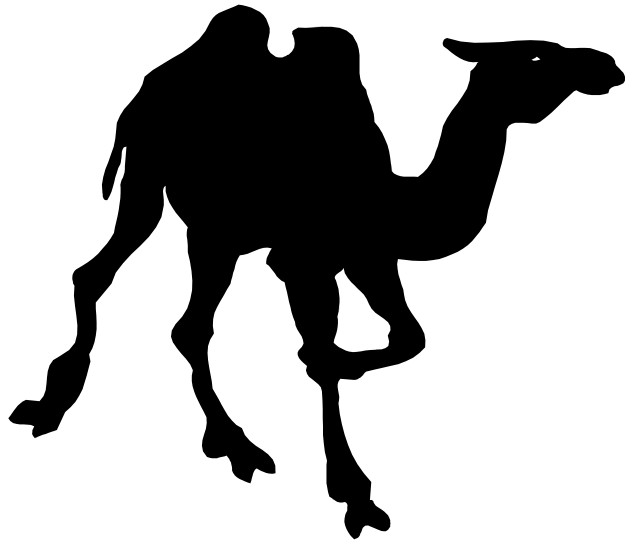

• Ha le gobbe ed è utile nel trasporto. Vive nel deserto.

- Ha la criniera, ruggisce e vive nella savana.

ASSOCIAZIONI VERBALI

Far associare ogni frase all'immagine corrispondente.

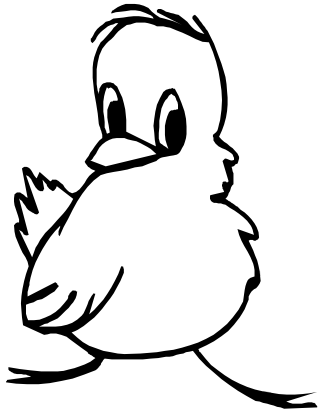

- Ha la pelliccia ed abbaia.
- Ha le piume e pigola.
- Ha le penne e chioccia.

ASSOCIAZIONI VERBALI

Far associare ogni frase all'immagine corrispondente.

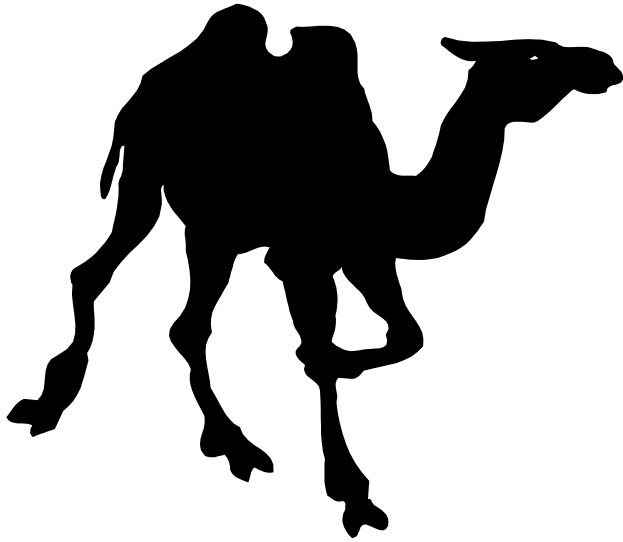

● E' feroce si ciba di carne è un ... "carnivoro"

- E' domestico e si ciba di vegetali è un ...
"erbivoro"

ASSOCIAZIONI VERBALI

Far associare ogni frase all'immagine corrispondente.

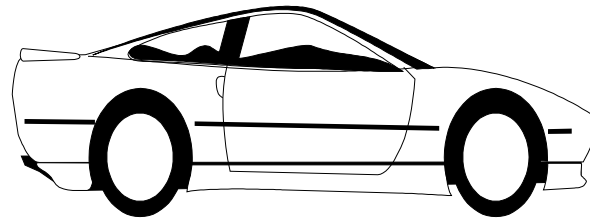

- Ha le ruote e corre sulla strada asfaltata.
- Ha il guscio e striscia sul terreno erboso.
- Ha le punte e si ferma sul fondale marino.

ASSOCIAZIONI VERBALI

Far associare ogni frase all'immagine corrispondente.

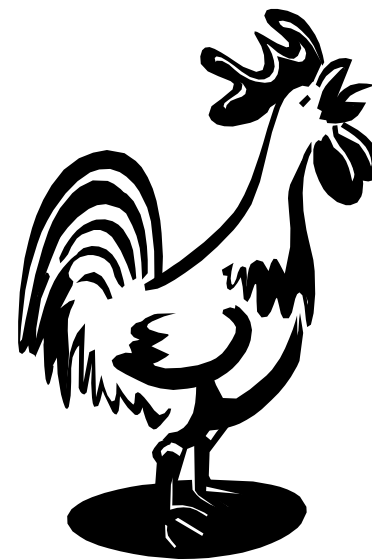

- Abbaia
 - Ruggisce
 - Canta

ASSOCIAZIONI VERBALI

Far associare ogni frase all'immagine corrispondente.

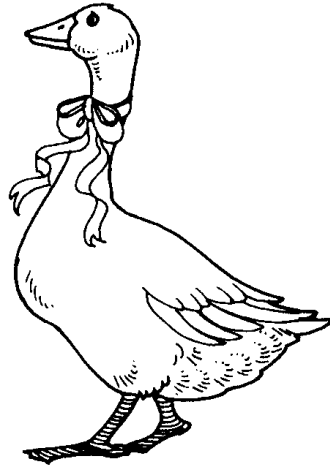
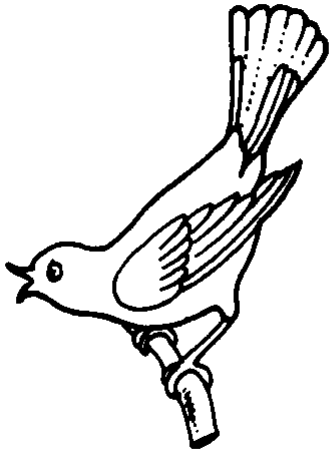

• Ha le ali e vola nell'aria.

• Ha la pelle viscida e salta sull'erba.

• Ha le zampe palmate e nuota nel laghetto.

ASSOCIAZIONI VERBALI

Far associare ogni frase all'immagine corrispondente.

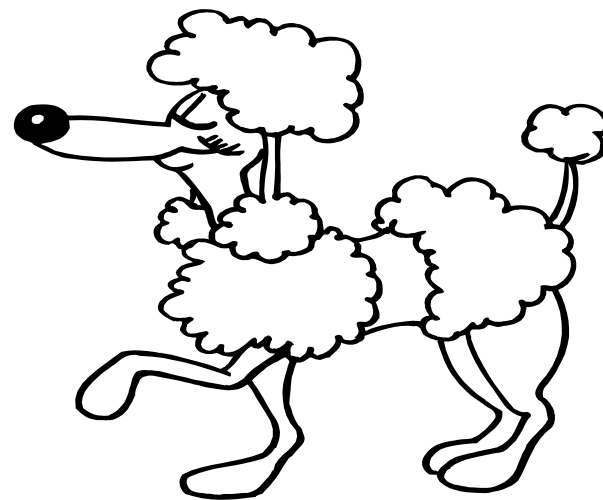
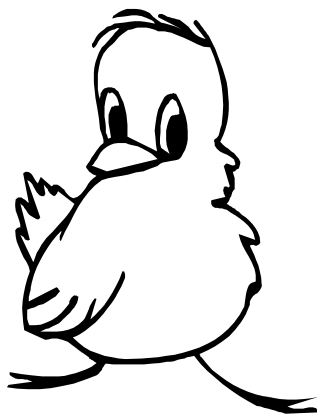
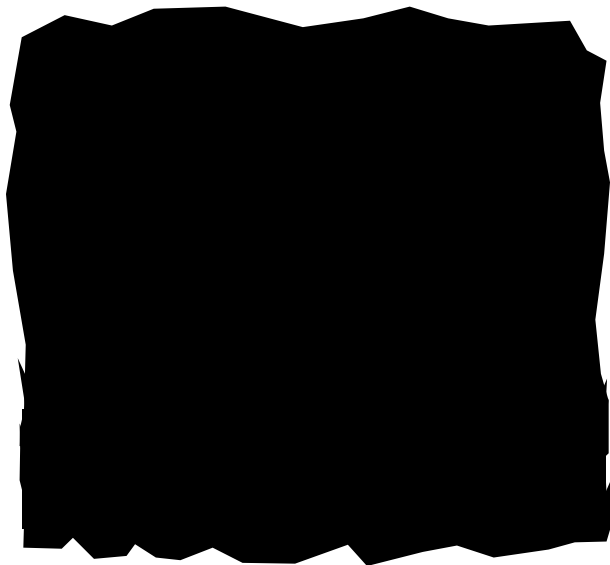

- Ha il becco e pigola nell'aia.
- Ha il muso allungato e abbaia nel cortile.
- Ha il muso schiacciato e grugnisce nel porcile.

ASSOCIAZIONI VERBALI

Far associare ogni frase all'immagine corrispondente.